

**ПРОТЯЖКИ ДЛЯ ШЛИЦЕВЫХ ОТВЕРСТИЙ С ЭВОЛЬВЕНТНЫМ  
ПРОФИЛЕМ ДИАМЕТРОМ ОТ 45 ДО 90 ММ,  
МОДУЛЕМ ОТ 3 ДО 5 ММ С ЦЕНТРИРОВАНИЕМ  
ПО НАРУЖНОМУ ДИАМЕТРУ**

**Конструкция и размеры**

**ГОСТ  
25160—82**

Broaches with diameter from 45 to 90 mm for slitting holes with involute profile and centring at outside diameter with modul from 3 to 5 mm.  
Construction and dimensions.

ОКП 39 2340

Постановлением Государственного комитета СССР по стандартам от 3 марта 1982 г. № 937 срок введения установлен

с 01.01. 1984 г.

Несоблюдение стандарта преследуется по закону

1. Настоящий стандарт распространяется на однопроходные протяжки диаметром от 45 до 90 мм, модулем от 3 до 5 мм, предназначенные для обработки шлицевых втулок с эвольвентным профилем по ГОСТ 6033—80 с центрированием по наружному диаметру.

2. Конструкция и размеры протяжек должны соответствовать указанным на черт. 1 и в табл. 1—3.

3. Размеры протягиваемого отверстия и усилие протягивания должны соответствовать указанным на черт. 2 и в табл. 4.

4. Наибольшие расчетные усилия протягивания  $P$  указаны для обработки деталей из стали I—IV групп обрабатываемости по ГОСТ 20365—74.

Для определения усилия протягивания для закаленных сталей и других материалов следует величину  $P$  умножить на коэффициент  $K$ , указанный в ГОСТ 25158—82.

5. Центровые отверстия — формы В или Т по ГОСТ 14034—74.

6. Хвостовики — типа 2, исполнения 1 по ГОСТ 4044—70.

Изготовление протяжек с хвостовиком типа 2 исполнений 2, 3 или 4 оговаривается заказом.

Лыски на хвостовиках должны располагаться перпендикулярно оси впадины профиля протяжки.

Допуск перпендикулярности на 10 мм ширины лыски не должен превышать 0,015 мм.

Длина лыски на заднем хвостовике оговаривается заказом.

7. Неуказанные предельные отклонения размеров: отверстий H14, валов h14, остальных  $\pm \frac{IT14}{2}$ .

8. Допуск симметричности боковых поверхностей фасочных зубьев относительно боковых поверхностей шлицевых зубьев не должен превышать 0,05 мм.

9. Форма и размеры профиля зубьев протяжек, группы заточки, форма передней грани зубьев протяжек — по ГОСТ 20365—74.

10. Задний угол зубьев протяжек должен быть:

черновых и переходных . . . . .	3°
чистовых . . . . .	2°
калибрующих . . . . .	1°

11. Пределы длины протягивания заготовок из чугуна, бронзы и латуни — справочные. Для протягивания заготовок из этих материалов с длиной протягивания, превышающей верхний предел длины протягивания по стали, следует заказывать протяжки по специальным чертежам с увеличенной длиной до первого зуба  $l_1$  и соответственно общей длиной протяжки.

Примечание. Длины протягивания указаны для протяжек из быстрорежущей стали по ГОСТ 19265—73 и стали марки ХВГ — по ГОСТ 5950—73.

12. Технические требования — по ГОСТ 6767—79.



Таблица 1

Размеры в мм

Обозначение протяжки	Приме- няе- мость	Обозначение протяжки	Приме- няе- мость	D×m	z	Сочетание полей допусков D и e	S	D <sub>1</sub>	D <sub>2</sub>	D <sub>3</sub> , не более	D <sub>4</sub> (пред. откл. -0,2)	D <sub>5</sub>	D <sub>6</sub>	D <sub>7</sub>	L		l	l <sub>1</sub>	l <sub>2</sub>	l <sub>3</sub>	l <sub>4</sub>	l <sub>5</sub>
															Испол- нение 1	Испол- нение 2						
2403-0961		2403-0962		45×3	13	H7-9H	6,342	36	39	38,4	44,3	36		44,6	1175	1300	8,0	356	117	546	81	55
2403-0963		2403-0964	H8-11H			6,411	1275								1400	9,5	382	135	585	99	80	
2403-0965		2403-0966	H7-9H			6,342	1175								1300	8,0	371	130	533	81	55	
2403-0967		2403-0968	H8-11H			6,411	1300								1425	9,5	397	135	585	99	80	
2403-0969		2403-0971		48×3	14	H7-9H	6,342	40	42	41,4	47,3	39		48,0	1175	1300	8,0	371	130	533	81	55
2403-0972		2403-0973	H8-11H			6,411	1300								1425	9,5	397	135	585	99	80	
2403-0974		2403-0975	H7-9H			6,342	1175								1300	8,0	371	130	533	81	55	
2403-0976		2403-0977	H8-11H			6,411	1200								1325	11,0	403	128	496	99	80	
2403-0978		2403-0979		50×3	15	H7-9H	5,765	44	43,4	49,3	41	36		49,4	1175	1300	8,0	371	130	533	81	55
2403-0981		2403-0982	H8-11H			5,834	1200								1325	11,0	403	128	496	99	80	
2403-0983		2403-0984	H7-9H			5,765	1175								1300	8,0	371	117	546	81	55	
2403-0985		2403-0986	H8-11H			5,834	1200								1325	11,0	403		512	99	80	
2403-0987		2403-0988		52×3	16	H7-9H	5,188	46	45,4	51,3	43			52,0	1175	1300	8,0	371	117	546	81	55
2403-0989		2403-0991	H8-11H			5,257	1200								1325	11,0	403		512	99	80	
2403-0992		2403-0993	H7-9H			5,188	1150								1275	9,5	377		504	90	60	
2403-0994		2403-0995	H8-11H			5,257	1150								1275	9,5	377		504	90	60	
2403-0996		2403-0997		55×3	17	H7-9H	5,197	49	48,4	54,3	46			55,0	1150	1275	9,5	377	112	504	90	60
2403-0998		2403-0999	H8-11H			5,277	1300								1425	11,0	415	128	576	99	90	
2403-1001		2403-1002	H7-9H			5,197	1150								1275	9,5	377	112	504	90	60	
2403-1003		2403-1004	H8-11H			5,277	1300								1425	11,0	415	128	576	99	90	
2403-1005		2403-1006		60×3	18	H7-9H	6,351	50	54	53,4	59,3	51	50	59,6	1150	1275	9,5	377	112	504	90	60
2403-1007		2403-1008	H8-11H			6,431	1300								1425	11,0	415	144	560	99	90	
2403-1009		2403-1011	H7-9H			6,351	1150								1275	9,5	377	112	504	90	60	
2403-1012		2403-1013	H8-11H			6,431	1300								1425	11,0	415	144	560	99	90	

## Размеры в мм

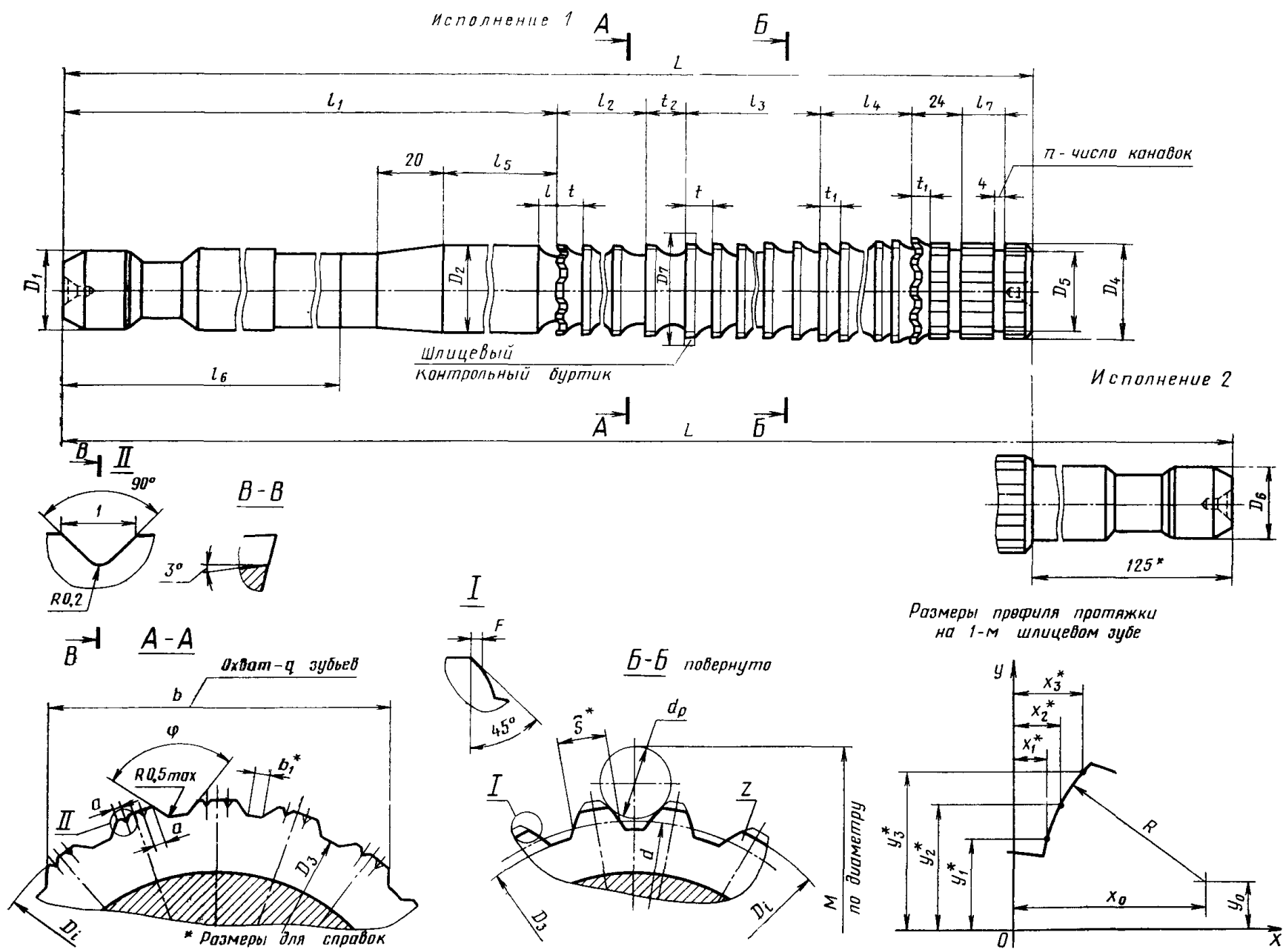
Обозначение протяжки		l <sub>а</sub>	l <sub>г</sub>	Зубья черновые и переходные				Зубья чистовые и калибрующие (число зубьев—10)		t <sub>а</sub>	b (пред. откл. —0,04)	b <sub>а</sub>	φ (пред. откл. ±1°)	q	F, не более	C		n	a	j									
Исполнение 1	Исполнение 2			Число зубьев		t	Номер профиля	t <sub>а</sub>	Номер профиля							Исполнение 1	Исполнение 2												
				фасочных	шлицевых																								
2403-0961	2403-0962	265	14		42	13	9	9	5	17	30,53	1,49	110°42'	4	0,24	0,294	0,325	3	1,5	24									
2403-0963	2403-0964			10																			0,319	0,350			22		
2403-0965	2403-0966					39	15	10	11	7						18													
2403-0967	2403-0968																												
2403-0969	2403-0971	280	13								31,07	1,74	102°42'	4	0,24	0,294	0,325	2	1,5	24									
2403-0972	2403-0973			11		41	13	9	9	5						17													
2403-0974	2403-0975																												
2403-0976	2403-0977			16		10	39	15	10	11						7	18												
2403-0978	2403-0979	288									30,89	1,83	96°00'	4	0,24	0,294	0,325	2	1,5	21									
2403-0981	2403-0982																												
2403-0983	2403-0984					9	31	16	11	11						7													
2403-0985	2403-0986			13																									
2403-0987	2403-0988	280			10	42	13	9	9	5	18																		
2403-0989	2403-0991	288									36,85	1,33	112°30'	4	0,24	0,294	0,325	2	1,5	20									
2403-0992	2403-0993					8	32	16	11	11						7													
2403-0994	2403-0995																												
2403-0996	2403-0997			14				14	10	10						6	17												
2403-0998	2403-0999	290									37,65	1,50	106°10'	5	0,24	0,288	0,319	2	1,5	18									
2403-1001	2403-1002			16		9	36	16	11	11						7	18												
2403-1003	2403-1004																												
2403-1005	2403-1006			14				14	10	10						6	17												
2403-1007	2403-1008	280									39,63	1,79	100°00'	4	0,24	0,288	0,319	2	1,5	19									
2403-1009	2403-1011			16		10	35	16	11	11						7	18												
2403-1012	2403-1013																												

## Размеры в мм

Обозначение протяжки	Приме- няе- мость	Обозначение протяжки	Приме- няе- мость	D×t	z	Сочетание полей допус- ков D и e	S	D <sub>1</sub>	D <sub>2</sub>	D <sub>3</sub> , не более	D <sub>4</sub> (пред. откл. -0,2)	D <sub>5</sub>	D <sub>6</sub>	D <sub>7</sub>	L		l	l <sub>1</sub>	l <sub>2</sub>	l <sub>3</sub>	l <sub>4</sub>	l <sub>5</sub>									
															Испол- нение 1	Испол- нение 2															
Исполнение 1		Исполнение 2																													
2403-1014		2403-1015		65×3	20	H7—9H	5,774	50	59	58,4	64,3	56	65,0		1150	1275	9,5	377	112	504	90	60									
2403-1016		2403-1017				H8—11H	5,854																								
2403-1018		2403-1019				H7—9H	5,774																	1325	1450	12,0	425	126	576	117	100
2403-1021		2403-1022				H8—11H	5,854																								
2403-1023		2403-1024		70×3	22	H7—9H	5,197	50	64	63,4	69,3	61	70,0		1175	1300	9,5	391	112	504	90	70									
2403-1025		2403-1026				H8—11H	5,277																								
2403-1027		2403-1028				H7—9H	5,197																	1350	1475	12,0	435	144	558	117	110
2403-1029		2403-1031				H8—11H	5,277																								
2403-1032		2403-1033		75×3	24	H7—9H	4,619	50	69	68,4	74,3	66	74,4		1200	1325	9,5	411	112	504	90	70									
2403-1034		2403-1035				H8—11H	4,699																								
2403-1036		2403-1037				H7—9H	4,619																	1375	1500	12,0	455	126	576	117	110
2403-1038		2403-1039				H8—11H	4,699																								
2403-1041		2403-1042		80×3	25	H7—9H	5,774	63	74	73,4	79,3	71	80,0		1200	1325	9,5	411	112	504	90	70									
2403-1043		2403-1044				H8—11H	5,854																								
2403-1045		—				H7—9H	5,774																	1475	—	12,0	465	152	646	126	110
2403-1046		—				H8—11H	5,854																								
2403-1047		2403-1048		85×3	27	H7—9H	5,197	63	79	78,4	84,3	76	85,3		1200	1325	9,5	411	112	504	90	70									
2403-1049		2403-1051				H8—11H	5,277																								
2403-1052		—				H7—9H	5,197																	1500	—	14,0	472	160	640	126	110
2403-1053		—				H8—11H	5,277																								
2403-1054		2403-1055		90×3	28	H7—9H	6,351	63	84	83,4	89,3	81	90,0		1200	1325	9,5	411	112	504	90	70									
2403-1056		2403-1057				H8—11H	6,431																								
2403-1058		—				H7—9H	6,351																	1500	—	12,0	465	171	646	126	110
2403-1059		—				H8—11H	6,431																								

## Размеры в мм

Обозначение протяжки		l <sub>6</sub>	l <sub>7</sub>	Зубья черновые и переходные				Зубья чистовые и калибрующие (число зубьев—10)		t <sub>2</sub>	b (пред. откл. —0,04)	b <sub>1</sub>	φ (пред. откл. ±1°)	g	F, не более	C		n	a	j
Исполнение 1	Исполнение 2			Число зубьев		t	Номера профиля	t <sub>1</sub>	Номер профиля							Исполнение 1	Исполнение 2			
				фасочных	шлицевых															
2403-1014	2403-1015	280	14	9	36	14	10	10	6	17	46,24	1,50	108°00'	6	0,288	0,319	2	1,5	18	
2403-1016	2403-1017																			
2403-1018	2403-1019	290		8	32	18	12	13	8	18	46,74	1,73	98°22'		0,331	0,362	3		16	
2403-1021	2403-1022																			
2403-1023	2403-1024	285		9	36	14	10	10	6	17	53,22	1,58	105°00'		0,294	0,325	4		14	
2403-1025	2403-1026																			
2403-1027	2403-1028	290		8	32	18	12	13	8	18	55,18	1,73	100°24'		0,344	0,375	4		14	
2403-1029	2403-1031																			
2403-1032	2403-1033	305		9	36	14	10	10	6	17	55,66	1,88	93°20'		0,300	0,331	3		18	
2403-1034	2403-1035																			
2403-1036	2403-1037	310		8	32	18	12	13	8	18	64,05	1,72	102°52'		0,375	—	4		19	
2403-1038	2403-1039																			
2403-1041	2403-1042	305		16	36	14	10	10	6	17	55,66	1,88	93°20'		0,300	0,331	3		18	
2403-1043	2403-1044																			
2403-1045	—	320	34		19	12	14	9	19	17	55,66	1,88	93°20'	0,369	—	3	17			
2403-1046	—																			
2403-1047	2403-1048	305	9		36	14	10	10	6	17	55,66	1,88	93°20'	0,300	0,331	3	18			
2403-1049	2403-1051																			
2403-1052	—	325	32		20	13	14	9	20	17	55,66	1,88	93°20'	0,375	—	4	17			
2403-1053	—																			
2403-1054	2403-1055	305	36		14	10	10	6	17	17	55,66	1,88	93°20'	0,300	0,331	3	18			
2403-1056	2403-1057																			
2403-1058	—	320	10		34	19	12	14	9	19	64,05	1,72	102°52'	0,375	—	4	19			
2403-1059	—																			

## Размеры в мм

Обозначение протяжки	Приме- няе- мость	Обозначение протяжки	Приме- няе- мость	D×m	z	Сочетание релей допус- ков D и e	S	D <sub>1</sub>	D <sub>2</sub>	D <sub>3</sub> , не более	D <sub>4</sub> (пред. откл. -0,2)	D <sub>5</sub>	D <sub>6</sub>	D <sub>7</sub>	L		l	l <sub>1</sub>	l <sub>2</sub>	l <sub>3</sub>	l <sub>4</sub>	l <sub>5</sub>									
															Испол- нение 1	Испол- нение 2															
Исполнение 1		Исполнение 2																													
2403-1061		2403-1062		55×3,5	14	H7—9H	6,810	45	48	47,4	54,3	45	36	54,7	1275	1400	9,5	377	126	602	90	60									
2403-1063		2403-1064				H8—11H	6,879																								
2403-1065		—				H7—9H	6,810																	1425	—	11,0	415	144	688	99	90
2403-1066		—				H8—11H	6,879																								
2403-1067		2403-1068		60×3,5	16	H7—9H	5,664	50	53	52,4	59,3	50	60,3		1275	1400	9,5	377	112	616	90	60									
2403-1069		2403-1071				H8—11H	5,744																								
2403-1072		—				H7—9H	5,664																1425	—	11,0	415	144	688	99	90	
2403-1073		—				H8—11H	5,744																								
2403-1074		2403-1075		65×3,5	18	H7—9H	4,510	50	58	57,4	64,3	55	64,8		1275	1400	9,5	377	126	602	90	60									
2403-1076		2403-1077				H8—11H	4,590																								
2403-1078		—				H7—9H	4,510																1450	—	12,0	425	162	648	117	100	
2403-1079		—				H8—11H	4,590																								
2403-1081		2403-1082		70×3,5	18	H7—9H	7,396	60	63	62,4	69,3	60	50	69,8		1275	1400	9,5	391	126	602	90	70								
2403-1083		2403-1084				H8—11H	7,476																								
2403-1085		—				H7—9H	7,396																	1450	—	12,0	435	162	648	117	110
2403-1086		—				H8—11H	7,476																								
2403-1087		2403-1088		75×3,5	20	H7—9H	6,242	65	68	67,4	74,3	65	75,4		1300	1425	9,5	411	112	616	90	70									
2403-1089		2403-1091				H8—11H	6,322																								
2403-1092		—				H7—9H	6,242																1475	—	12,0	455	144	666	117	110	
2403-1093		—				H8—11H	6,322																								
2403-1094		2403-1095		80×3,5	22	H7—9H	5,087	63	73	72,4	79,3	70	79,7		1300	1425	9,5	411	126	602	90	70									
2403-1096		2403-1097				H8—11H	5,167																								
2403-1098		—				H7—9H	5,087																1475	—	12,0	455	144	666	117	110	
2403-1099		—				H8—11H	5,167																								

## Размеры в мм

Обозначение протяжек		l <sub>6</sub>	l <sub>7</sub>	Зубья черновые и переходные				Зубья чистовые и калибрующие (число зубьев—10)		t <sub>2</sub>	b (пред. откл. -0,04)	b <sub>1</sub>	φ (пред. откл. ±1°)	q	F. не более	C		n	a	j	
Исполнение 1	Исполнение 2			Число зубьев		t	Номер профиля	t <sub>1</sub>	Номер профиля							Исполнение 1	Исполнение 2				
				фасочных	шлицевых																
2403-1061	2403-1062	280	14	10	43	14	10	10	6	17	35,51	2,10	102°42'	4	0,319	0,350	3	2,0	19		
2403-1063	2403-1064	290				16	11	11	7												
2403-1065	—			280	9	44	14	10	10	6	18	42,44	1,70	112°30'	5	0,319				0,350	4
2403-1066	—	290					16	11	11	11											
2403-1067	2403-1068			280	10	36			18	12	13	8	18	46,20	2,26	100°00'				0,362	—
2403-1069	2403-1071	290					13	36	18	12	13	8									
2403-1072	—			285	14	43			14	10	10	6	17	53,26	2,20	98°22'				0,369	—
2403-1073	—	290					16	10	18	12	13	8									
2403-1074	2403-1075			280	10	44			14	10	10	6	17	53,26	2,20	98°22'				0,369	—
2403-1076	2403-1077	290					13	36	18	12	13	8									
2403-1078	—			290	16	10			18	12	13	8	18	53,26	2,20	98°22'				0,369	—
2403-1079	—	285					14	43	14	10	10	6									
2403-1081	2403-1082			285	14	43			14	10	10	6	17	53,26	2,20	98°22'				0,369	—
2403-1083	2403-1084	290					13	36	18	12	13	8									
2403-1085	—		290	13	36	18			12	13	8	18	53,26	2,20	98°22'	0,369	—	4	13		
2403-1086	—	305				12	44	14	10	10	6									17	53,26
2403-1087	2403-1088		305	12	44			14	10	10	6	17	53,26	2,20	98°22'	0,369	—	4	13		
2403-1089	2403-1091	310				14	37	18	12	13	8									18	53,26
2403-1092	—		310	14	37			18	12	13	8	18	53,26	2,20	98°22'	0,369	—	4	13		
2403-1093	—	305				12	10	14	10	10	6									17	53,26
2403-1094	2403-1095		305	12	10			14	10	10	6	17	53,26	2,20	98°22'	0,369	—	4	13		
2403-1096	2403-1097	310				14	9	37	18	12	13									18	53,26
2403-1098	—		310	14	9			37	18	12	13	18	53,26	2,20	98°22'	0,369	—	4	13		
2403-1099	—	310				14	9	37	18	12	13									18	53,26



Размеры в мм

Обозначение протяжки	Приме- няе- мость	Обозначение протяжки	Приме- няе- мость	D×m	z	Сочетание полей допус- ков D и e	S	D <sub>1</sub>	D <sub>2</sub>	D <sub>3</sub> , не более	D <sub>4</sub> (пред. откл. -0,2)	D <sub>5</sub>	D <sub>6</sub>	D	L		l	l <sub>1</sub>	l <sub>2</sub>	l <sub>3</sub>	l <sub>4</sub>	l <sub>5</sub>														
															Испол- нение 1	Испол- нение 2																				
Исполнение 1		Исполнение 2																																		
2403-1101		2403-1102		85×3,5	24	H7—9H	3,932	63	78	77,4	84,3	75	85,3		1300	1425	9,5	411	112	616	90	70														
2403-1103		2403-1104				H8—11H	4,012																													
2403-1105		—				H7—9H	3,932																1500	—	12,0	455	144	684	117	110						
2403-1106		—				H8—11H	4,012																													
2403-1107		2403-1108		90×3,5		H7—9H	6,819		83	82,4	89,3	80	90,3	1300	1425		411	126	602	90	70															
2403-1109		2403-1111				H8—11H	6,899																	9,5												
2403-1112		2403-1113		60×4	13	H7—9H	8,442	50					59,0		1375	1500	9,5	377	140	686	90	60														
2403-1114		2403-1115				H8—11H	8,522																1475	—	11,0	410	144	736	99	90						
2403-1116		—				H7—9H	8,442																													
2403-1117		—				H8—11H	8,522																													
2403-1118		2403-1119		65×4	15	H7—9H	6,710	50					65,0		1375	1500	9,5	377	154	672	90	60														
2403-1121		2403-1122				H8—11H	6,790																1475	—	11,0	410	160	720	99	90						
2403-1123		—				H7—9H	6,710																													
2403-1124		—				H8—11H	6,790																													
2403-1125		2403-1126		70×4	16	H7—9H	7,287		62	61,2	69,2	59	70,4	1375	1500		391	126	700																	
2403-1127		2403-1128				H8—11H	7,367																													
2403-1129		2403-1131		75×4	17	H7—9H	7,864		67	66,2	74,2	64	74,6																							
2403-1132		2403-1133				H8—11H	7,944																	140	686											
2403-1134		2403-1135		80×4	18	H7—9H	8,442		72	71,2	79,2	69	79,6				9,5				90	70														
2403-1136		2403-1137				H8—11H	8,522																													
2403-1138		2403-1139		85×4	20	H7—9H	6,710		77	76,2	84,2	74	84,8	1400	1525		411	126	700																	
2403-1141		2403-1142				H8—11H	6,790																													
2403-1143		2403-1144		90×4	21	H7—9H	7,287		82	81,2	89,2	79	89,3						140	686																
2403-1145		2403-1146				H8—11H	7,367																													

## Размеры в мм

Обозначение протяжки		l <sub>6</sub>	l <sub>7</sub>	Зубья черновые и переходные				Зубья чистовые и калибрующие (число зубьев-10)		t <sub>2</sub>	b (пред. откл. -0,04)	b <sub>1</sub>	α (пред. откл. ±1°)	q	F, не более	C		n	a	i
Исполнение 1	Исполнение 2			Число зубьев		t	Номер профиля	t <sub>1</sub>	Номер профиля							Исполнение 1	Исполнение 2			
				фасочных	шлицевых															
2403-1101	2403-1102	305	12	9	44	14	10	10	6	18	60,00	2,12	105°00'	7	0,28	0,325	0,356	3	2,0	5
2403-1103	2403-1104															0,375	—			
2403-1105	—	310	16	9	38	18	12	13	8	18	64,02	2,05	105°00'	7	0,28	0,375	—	4	2,0	5
2403-1106	—															0,375	—			
2403-1107	2403-1108	305	12	10	43	14	10	10	6	18	64,02	2,05	105°00'	7	0,28	0,325	0,356	3	2,0	20
2403-1109	2403-1111															0,325	0,356			
2403-1112	2403-1113	280	14	11	49	14	10	10	6	18	40,68	2,04	110°42'	4	0,32	0,344	0,375	3	2,0	23
2403-1114	2403-1115															0,344	0,375			
2403-1116	—	285	16	10	46	16	11	11	7	18	40,68	2,04	110°42'	4	0,32	0,369	—	3	2,0	21
2403-1117	—															0,369	—			
2403-1118	2403-1119	280	16	12	48	14	10	10	6	17	39,97	2,40	96°00'	4	0,32	0,344	0,375	3	2,5	17
2403-1121	2403-1122															0,344	0,375			
2403-1123	—	285	14	11	45	16	11	11	7	18	39,97	2,40	96°00'	5	0,32	0,369	—	3	2,5	16
2403-1124	—															0,369	—			
2403-1125	2403-1126	285	14	10	50	14	10	10	6	18	49,65	1,85	112°30'	5	0,32	0,344	0,375	2	2,5	18
2403-1127	2403-1128															0,344	0,375			
2403-1129	2403-1131	305	12	11	49	14	10	10	6	18	51,43	2,17	106°10'	6	0,32	0,350	0,381	3	2,5	20
2403-1132	2403-1133															0,350	0,381			
2403-1134	2403-1135	305	12	11	49	14	10	10	6	18	52,79	2,48	100°00'	6	0,32	0,350	0,381	3	2,5	21
2403-1136	2403-1137															0,350	0,381			
2403-1138	2403-1139	305	12	10	50	14	10	10	6	18	60,29	2,06	108°00'	6	0,32	0,350	0,381	3	2,5	17
2403-1141	2403-1142															0,350	0,381			
2403-1143	2403-1144	305	12	11	49	14	10	10	6	18	62,06	2,23	103°03'	6	0,32	0,350	0,381	3	2,5	20
2403-1145	2403-1146															0,350	0,381			

Размеры в мм

Обозначение протяжки	Приме- няе- мость	Обозначение протяжки	Приме- няе- мость	D×m	z	Сочетание полей допус- ков D и e	S	D <sub>1</sub>	D <sub>2</sub>	D <sub>3</sub> , не более	D <sub>4</sub> (пре- ткл. -0,2)	D <sub>5</sub>	D <sub>6</sub>	D <sub>7</sub>	L		l	l <sub>1</sub>	l <sub>2</sub>	l <sub>3</sub>	l <sub>4</sub>	l <sub>5</sub>
															Испол- нение 1	Испол- нение 2						
2403-1147		—		70×5	12	H7—9H	10,542	50	60	59,0	69,0	57	70,0	1475				389	128	784		
2403-1148		—				H8—11H	10,632															
2403-1149		—		75×5	13	H7—9H	10,542		65	64,0	74,0	62	74,0									
2403-1151		—				H8—11H	10,632															
2403-1152		—		80×5	14	H7—9H	10,542	63	70	69,0	79,0	67	50	79,5	1500	—	11	409	144	768	99	70
2403-1153		—				H8—11H	10,632															
2403-1154		—		85×5	15	H7—9H	10,542		75	74,0	84,0	72	84,4									
2403-1155		—				H8—11H	10,632															
2403-1156		—		90×5	16	H7—9H	10,542		80	79,0	89,0	77	90,0						128	784		
2403-1157		—				H8—11H	10,632															

Продолжение табл. 1

Размеры в мм

Обозначение протяжки		l <sub>6</sub>	l <sub>7</sub>	Зубья черновые и переходные				Зубья чистовые и калибрующие (число зубьев—10)		t <sub>2</sub>	b (пред. откл. -0,04)	b <sub>1</sub>	γ (пред. откл. -1)	q	F, не более	C		n	a	j		
Исполнение 1	Исполнение 2			Число зубьев		t	Номер про- филя	число зубьев—10								t <sub>1</sub>	Номер профиля				Испол- нение 1	Испол- нение 2
				фасоч- ных	шли- цевых			t <sub>1</sub>	Номер профиля													
2403-1147	—	280	12	9	49						49,68	2,07	120°00'			0,369				30		
2403-1148	—																					
2403-1149	—										50,83	2,62	110°42'	4								
2403-1151	—																					
2403-1152	—	300	14	10	48	16	11	11	7	19	51,73	3,02	102°42'		0,40	0,375	—	3	3,0			
2403-1153	—																					
2403-1154	—										52,55	3,32	96°00'							29		
2403-1155	—																					
2403-1156	—			9	49						64,01	2,56	112°30'	5								
2403-1157	—																					

Пример условного обозначения протяжки длиной 1425 мм для шлицевого эвольвентного отверстия диаметром 60 мм, модулем 3 мм, с центрированием по наружному диаметру, полем допуска центрирующего диаметра H7 и ширины впадины 9H, группы заточки II исполнения 2:

Протяжка 2403-1011 II ГОСТ 25160—82

## Размеры в мм

Обозначение протяжки	DХм	Сочетание полей допусков D и e	x <sub>1</sub>	x <sub>2</sub>	x <sub>3</sub>	y <sub>1</sub>	y <sub>2</sub>	y <sub>3</sub>	x <sub>0</sub>	y <sub>0</sub>	R	d <sub>p</sub>	W	M		
														На буртике	На зубе номер W	На последнем калибрующем зубе
2403-0961 2403-0962	45X3	H7—9H	1,900	2,872	4,029	19,930	21,090	22,185	12,630	11,901	13,425	6,518	33	51,721	51,579	51,410
												8,282	—	56,088	—	55,777
												10,353	—	61,040	—	60,729
2403-0963 2403-0964		H8—11H	1,862	2,834	3,992	19,972	21,106	22,178	12,623	11,869	13,499	6,518	33	51,807	51,665	51,496
												8,282	—	56,164	—	55,853
												10,353	—	61,108	—	60,797
2403-0965 2403-0966		H7—9H	1,933	2,885	4,014	21,493	22,660	23,714	12,729	12,973	14,330	6,518	31	51,725	51,575	51,385
												8,282	—	56,095	—	55,755
												10,353	—	61,051	—	60,711
2403-0967 2403-0968	H8—11H	1,895	2,848	3,977	21,479	22,622	23,710	12,692	12,995	14,334	6,518	31	51,810	51,661	51,470	
											8,282	—	56,171	—	55,831	
											10,353	—	61,119	—	60,779	
2403-0969 2403-0971	48X3	H7—9H	1,939	2,901	3,976	21,493	22,660	23,714	13,461	12,973	14,330	6,518	34	55,107	54,964	54,800
												8,282	—	59,525	—	59,218
												10,353	—	64,534	—	64,227
2403-0972 2403-0973		H8—11H	1,902	2,864	3,939	21,479	22,622	23,710	13,424	12,995	14,334	6,518	34	55,195	55,052	54,888
												8,282	—	59,603	—	59,296
												10,353	—	64,605	—	64,298
2403-0974 2403-0975		H7—9H	1,928	2,862	3,961	21,479	22,622	23,710	13,481	12,995	14,334	6,518	31	55,115	54,965	54,773
												8,282	—	59,537	—	59,195
												10,353	—	64,550	—	64,208
2403-0976 2403-0977	H8—11H	1,891	2,825	3,924	21,479	22,622	23,710	13,444	12,995	14,334	6,518	31	55,203	55,053	54,861	
											8,282	—	59,616	—	59,274	
											10,353	—	64,621	—	64,279	

## Размеры в мм

Обозначение протяжки	D×m	Сочетание полей допус- ков D и e	x <sub>1</sub>	x <sub>2</sub>	x <sub>3</sub>	y <sub>1</sub>	y <sub>2</sub>	y <sub>3</sub>	x <sub>0</sub>	y <sub>0</sub>	R	d <sub>p</sub>	W	M		
														На буртике	На зубе номер W	На последнем калибрующем зубе
2403-0978 2403-0979	50×3	H7—9H	1,881	2,769	3,767	22,502	23,683	24,760	13,740	14,515	14,298	6,212	34	56,330	56,188	56,025
												7,000	—	58,372	—	58,067
												8,690	—	62,623	—	62,318
2403-0981 2403-0982		H8—11H	1,845	2,733	3,731	22,502	23,683	24,760	13,703	14,515	14,298	6,212	34	56,424	56,282	56,119
												7,000	—	58,461	—	58,156
												8,690	—	62,703	—	62,398
2403-0983 2403-0984		H7—9H	1,908	2,736	3,711	22,539	23,638	24,693	13,630	14,556	14,183	6,212	26	56,322	56,194	56,026
												7,000	—	58,361	—	58,065
												8,690	—	62,606	—	62,310
2403-0985 2403-0986		H8—11H	1,871	2,700	3,675	22,539	23,638	24,693	13,594	14,556	14,183	6,212	26	56,413	56,286	56,117
												7,000	—	58,447	—	58,151
												8,690	—	62,684	—	62,388
2403-0987 2403-0988	52×3	H7—9H	1,811	2,623	3,598	23,450	24,645	25,799	13,892	16,114	14,133	6,212	34	58,855	58,706	58,542
												7,000	—	60,948	—	60,635
												8,690	—	65,286	—	64,973
2403-0989 2403-0991		H8—11H	1,776	2,588	3,563	23,450	24,645	25,799	13,856	16,114	14,133	6,212	34	58,953	58,804	58,640
												7,000	—	61,040	—	60,727
												8,690	—	65,368	—	65,055
2403-0992 2403-0993		H7—9H	1,823	2,638	3,546	23,469	24,659	25,732	13,806	16,134	14,050	6,212	27	58,849	58,705	58,543
												7,000	—	60,938	—	60,632
												8,690	—	65,271	—	64,965
2403-0994 2403-0995		H8—11H	1,788	2,603	3,510	23,469	24,659	25,732	13,771	16,134	14,050	6,212	27	58,944	58,800	58,638
												7,000	—	61,027	—	60,721
												8,690	—	65,350	—	65,044

## Размеры в мм

Обозначение протяжки	$D \times t$	Сочетание ислей допус- ков $D$ и $e$	$x_1$	$x_2$	$x_3$	$y_1$	$y_2$	$y_3$	$x_0$	$y_0$	$R$	$d_p$	$W$	M		
														На буртике	На зубе номер $W$	На последнем калибрующем зубе
2403-0996 2403-0997	55×3	H7—9H	1,821	2,621	3,573				14,550			6,212	30	61,648	61,509	61,352
												7,000	—	63,743	—	63,447
												8,690	—	68,088	—	67,792
2403-0998 2403-0999		H8—11H	1,780	2,580	3,532	24,974	26,158	27,305	14,509	17,233	14,898	6,212	30	61,760	61,620	61,464
												7,000	—	63,848	—	63,552
												8,690	—	68,182	—	67,886
2403-1001 2403-1002		H7—9H	1,821	2,621	3,573				14,675			6,212	30	61,662	61,503	61,326
												7,000	—	63,761	—	63,425
												8,690	—	68,116	—	67,780
2403-1003 2403-1004	H8—11H	1,780	2,580	3,532		26,167	27,322	14,634	17,213	15,015	6,212	30	61,774	61,615	61,438	
											7,000	—	63,867	—	63,531	
											8,690	—	68,211	—	67,875	
2403-1005 2403-1006	60×3	H7—9H	1,893	2,785	3,813				16,297			6,212	30	66,502	66,362	66,205
												7,000	—	68,557	—	68,260
												8,690	—	72,851	—	72,554
2403-1007 2403-1008		H8—11H	1,851	2,742	3,770	27,475	28,654	29,795	16,255	17,514	17,513	6,212	30	66,610	66,470	66,313
												7,000	—	68,660	—	68,363
												8,690	—	72,944	—	72,647
2403-1009 2403-1011		H7—9H	1,942	2,842	3,813				16,482			6,212	30	66,505	66,353	66,175
												7,000	—	68,564	—	68,234
												8,690	—	72,866	—	72,536
2403-1012 2403-1013	H8—11H	1,899	2,799	3,770	27,542	28,727	29,808	16,439	17,445	17,702	6,212	30	66,613	66,461	66,283	
											7,000	—	68,667	—	68,337	
											8,690	—	72,960	—	72,630	

Размеры в мм

Обозначение протяжки	D×m	Сочетание полей допус- ков D и c	x <sub>1</sub>	x <sub>2</sub>	x <sub>3</sub>	y <sub>1</sub>	y <sub>2</sub>	y <sub>3</sub>	x <sub>0</sub>	y <sub>0</sub>	R	d <sub>p</sub>	W	M			
														На буртике	На зубе номер W	На последнем калибрующем зубе	
2403-1014 2403-1015	65×3	H7—9H	1,850	2,678	3,633				17,222			6,212	30	71,767	71,627	71,470	
												7,000	—	73,867	—	73,570	
												8,690	—	78,246	—	77,949	
2403-1016 2403-1017		H8—11H	1,808	2,637	3,592		31,174	32,335		17,180	20,179	18,232	6,212	30	71,881	71,741	71,584
													7,000	—	73,976	—	73,679
													8,690	—	78,345	—	78,048
2403-1018 2403-1019		H7—9H	1,850	2,686	3,582	29,983				17,359			6,212	27	71,778	71,616	71,432
													7,000	—	73,883	—	73,537
													8,690	—	78,271	—	77,925
2403-1021 2403-1022	H8—11H	1,808	2,644	3,541		31,192	32,292		17,317	20,151	18,363	6,212	27	71,894	71,731	71,547	
												7,000	—	73,993	—	73,646	
												8,690	—	78,370	—	78,023	
2403-1023 2403-1024	70×3	H7—9H	1,827	2,603	3,496				18,117			5,455	29	74,874	74,741	74,577	
												6,518	—	77,823	—	77,526	
												8,282	—	82,530	—	82,233	
2403-1025 2403-1026		H8—11H	1,787	2,562	3,455	32,489	33,689	34,864		18,076	22,815	18,945	5,455	29	74,998	74,865	74,701
													6,518	—	77,938	—	77,641
													8,282	—	82,633	—	82,336
2403-1027 2403-1028		H7—9H	1,876	2,610	3,448					18,274			5,455	26	74,877	74,733	74,539
													6,518	—	77,833	—	77,495
													8,282	—	82,549	—	82,211
2403-1029 2403-1031	H8—11H	1,835	2,569	3,408	32,566	33,702	34,815		18,234	22,772	19,101	5,455	26	74,999	74,855	74,662	
												6,518	—	77,945	—	77,608	
												8,282	—	82,650	—	82,313	

## Размеры в мм

Обозначение протяжки	D×m	Сочетание полей допус- ков D и e	x <sub>1</sub>	x <sub>2</sub>	x <sub>3</sub>	y <sub>1</sub>	y <sub>2</sub>	y <sub>3</sub>	x <sub>0</sub>	y <sub>0</sub>	R	d <sub>p</sub>	W	M			
														На буртике	На зубе номер W	На последнем калибрующем зубе	
2403-1032 2403-1033	75×3	H7—9H	1,821	2,551	3,392				18,895			5,455	29	79,999	79,866	79,702	
												6,212	—	82,158	—	81,861	
												7,000	—	84,349	—	84,052	
2403-1034 2403-1035		H8—11H	1,781	2,511	3,352		36,200	37,385		18,855	25,496	19,537	5,455	29	80,127	79,994	79,830
													6,212	—	82,279	—	81,982
													7,000	—	84,463	—	84,166
2403-1036 2403-1037		H7—9H	1,821	2,558	3,347		34,993			18,992			5,455	26	80,011	79,858	79,664
													6,212	—	82,175	—	81,828
													7,000	—	84,371	—	84,024
2403-1038 2403-1039	H8—11H	1,781	2,517	3,307		36,217	37,340		18,952	25,504	19,618	5,455	26	80,139	79,986	79,793	
												6,212	—	82,296	—	81,950	
												7,000	—	84,485	—	84,139	
2403-1041 2403-1042	80×3	H7—9H	1,850	2,651	3,554				20,776			5,455	29	84,616	84,483	84,320	
												6,518	—	87,546	—	87,250	
												8,282	—	92,249	—	92,253	
2403-1043 2403-1044		H8—11H	1,809	2,609	3,513		37,494	38,699	39,880	20,735	25,780	22,258	5,455	29	84,738	84,605	84,442
													6,518	—	87,661	—	87,365
													8,282	—	92,353	—	92,057
2403-1045		H7—9H	1,875	2,687	3,542					21,227			5,455	28	84,628	84,457	84,243
													6,518	—	87,572	—	87,187
													8,282	—	92,297	—	91,912
2403-1046	H8—11H	1,834	2,645	3,501		37,533	38,763	39,895	21,185	25,642	22,713	5,455	28	84,754	84,584	84,369	
												6,518	—	87,691	—	87,306	
												8,282	—	92,405	—	92,020	



Размеры в мм

Обозначение протяжки	DХ <sub>мм</sub>	Сочетание полей допус- ков D и e	x <sub>1</sub>	x <sub>2</sub>	x <sub>3</sub>	y <sub>1</sub>	y <sub>2</sub>	y <sub>3</sub>	x <sub>0</sub>	y <sub>0</sub>	R	d <sub>p</sub>	W	M		
														На буртике	На зубе номер W	На последнем калибрующем зубе
2403-1047 2403-1048	85×3	H7—9H	1,831	2,591	3,447	39,998	41,208	42,399	21,675	28,387	22,991	5,455	29	89,772	89,640	89,476
												6,518	—	92,760	—	92,464
												8,282	—	97,544	—	97,248
2403-1049 2403-1051		H8—11H	1,791	2,550	3,406	40,037	41,271	42,406	21,634	28,326	23,316	5,455	29	89,900	89,767	89,603
												6,518	—	92,880	—	92,583
												8,282	—	97,653	—	97,356
2403-1052		H7—9H	1,855	2,625	3,432	42,499	43,706	44,894	22,017	28,730	25,591	5,455	28	89,786	89,606	89,404
												6,518	—	92,788	—	92,406
												8,282	—	97,593	—	97,211
2403-1053	H8—11H	1,815	2,584	3,391	42,523	43,756	44,894	21,976	28,668	25,941	5,455	28	89,915	89,735	89,532	
											6,518	—	92,909	—	92,526	
											8,282	—	97,703	—	97,320	
2403-1054 2403-1055	90×3	H7—9H	1,878	2,698	3,609	42,499	43,706	44,894	23,449	28,730	25,591	6,212	30	96,758	96,618	96,461
												7,000	—	98,895	—	98,598
												8,282	—	102,301	—	102,004
2403-1056 2403-1057		H8—11H	1,836	2,656	3,567	42,523	43,756	44,894	23,408	28,668	25,941	6,212	30	96,874	96,734	96,577
												7,000	—	99,003	—	98,709
												8,282	—	102,406	—	102,109
2403-1058		H7—9H	1,894	2,723	3,585	42,523	43,756	44,894	23,825	28,668	25,941	6,212	29	96,779	96,608	96,393
												7,000	—	98,926	—	98,540
												8,282	—	102,348	—	101,962
2403-1059	H8—11H	1,852	2,682	3,543	42,523	43,756	44,894	23,784	28,668	25,941	6,212	29	96,898	96,727	96,512	
											7,000	—	99,041	—	98,655	
											8,282	—	102,456	—	102,070	

## Размеры в мм

Обозначение протяжки	$D \times m$	Сочетание полей допус- ков $D$ и $e$	$\lambda_1$	$\lambda_2$	$\lambda_3$	$y_1$	$y_2$	$y_3$	$x_0$	$y_0$	$R$	$d_p$	$W$	M			
														На буртике	На зубе номер $W$	На последнем калибрующем зубе	
2403-1061 2403-1062	55×3,5	H7—9H	2,164	3,215	4,475	24,515	25,880	27,182	15,125	15,620	15,720	7,000	33	61,959	61,805	61,613	
												8,690	—	66,300	—	65,954	
												10,950	—	71,886	—	71,540	
2403-1063 2403-1064		H8—11H	2,127	3,179	4,438		15,088	25,890	27,202	15,245	15,602	15,829	7,000	33	62,049	61,895	61,703
													8,690	—	66,381	—	66,035
													10,950	—	71,958	—	71,612
2403-1065		H7—9H	2,164	3,215	4,475		15,245	25,890	27,202	15,209	15,602	15,829	7,000	33	61,970	61,794	61,577
													8,690	—	66,320	—	65,927
													10,950	—	71,917	—	71,524
2403-1066	H8—11H	2,127	3,179	4,438	15,209	26,961	28,423	29,769	15,709	19,143	15,723	7,000	33	62,063	61,887	61,669	
												8,690	—	66,404	—	66,010	
												10,950	—	71,991	—	71,597	
2403-1067 2403-1068	H7—9H	2,067	3,016	4,119	15,709	26,961	28,423	29,769	15,709	19,143	15,723	7,000	34	67,445	67,277	67,092	
												8,690	—	71,952	—	71,599	
												10,353	—	76,208	—	75,855	
2403-1069 2403-1071	H8—11H	2,026	2,976	4,079	15,668	27,028	28,430	29,785	15,668	19,088	15,898	7,000	34	67,561	67,393	67,208	
												8,690	—	72,055	—	71,702	
												10,353	—	76,302	—	75,949	
2403-1072	H7—9H	2,107	3,016	4,119	15,880	27,028	28,430	29,785	15,880	19,088	15,898	7,000	34	67,458	67,274	67,064	
												8,690	—	71,975	—	71,581	
												10,353	—	76,240	—	75,846	
2403-1073	H8—11H	2,066	2,976	4,079	15,840	27,028	28,430	29,785	15,840	19,088	15,898	7,000	34	67,571	67,387	67,178	
												8,690	—	72,076	—	71,683	
												10,353	—	76,331	—	75,938	

## Размеры в мм

Обозначение протяжки	$D \times m$	Сочетание полей допус- ков $D$ и $e$	$x_1$	$x_2$	$x_3$	$y_1$	$y_2$	$y_3$	$x_0$	$y_0$	$R$	$d_p$	$W$	М		
														На буртике	На зубе номер $W$	На последнем калибрующем зубе
2403-1074 2403-1075	65×3,5	H7—9H	2,127	2,916	3,890	29,534	30,943	32,316	16,108	22,621	15,597	6,518	34	71,365	71,204	71,019
												8,282	—	76,339	—	75,993
												8,690	—	77,446	—	77,100
2403-1076 2403-1077		H8—11H	2,087	2,877	3,851	29,534	30,943	32,316	16,069	22,621	15,597	6,518	34	71,493	71,332	71,147
												8,282	—	76,449	—	76,103
												8,690	—	77,552	—	77,206
2403-1078		H7—9H	2,171	2,948	3,897	29,621	30,996	32,338	16,338	22,529	15,843	6,518	31	71,370	71,190	70,988
												8,282	—	76,355	—	75,973
												8,690	—	77,464	—	77,082
2403-1079	H8—11H	2,132	2,909	3,858	29,621	30,996	32,338	16,299	22,529	15,843	6,518	31	71,494	71,315	71,112	
											8,282	—	76,462	—	76,080	
											8,690	—	77,568	—	77,186	
2403-1081 2403-1082	70×3,5	H7—9H	2,202	3,249	4,459	32,034	33,422	34,764	18,993	20,451	20,399	7,000	33	76,913	76,759	76,567
												8,690	—	81,311	—	80,965
												10,950	—	86,992	—	86,646
2403-1083 2403-1084		H8—11H	2,160	3,207	4,416	32,034	33,422	34,764	18,951	20,451	20,399	7,000	33	77,023	76,869	76,677
												8,690	—	81,411	—	81,065
												10,950	—	87,083	—	86,737
2403-1085		H7—9H	2,264	3,290	4,468	32,120	33,475	34,786	19,209	20,357	20,628	7,000	30	76,914	76,743	76,532
												8,690	—	81,320	—	80,938
												10,950	—	87,012	—	86,630
2403-1086	H8—11H	2,222	3,247	4,425	32,120	33,475	34,786	19,166	20,357	20,628	7,000	30	77,027	76,856	76,645	
											8,690	—	81,423	—	81,041	
											10,950	—	87,105	—	86,723	

## Размеры в мм

Обозначение протяжки	D×m	Сочетание полей допус- ков D и e	x <sub>1</sub>	x <sub>2</sub>	x <sub>3</sub>	y <sub>1</sub>	y <sub>2</sub>	y <sub>3</sub>	x <sub>0</sub>	y <sub>0</sub>	R	d <sub>p</sub>	W	M		
														На буртике	На зубе номер W	На последнем калибрующем зубе
2403-1087 2403-1088	75×3,5	H7—9H	2,088	3,066	4,155	34,477	35,953	37,322	19,585	23,938	20,426	6,518	33	81,033	80,872	80,680
												8,282	—	85,820	—	85,467
												10,353	—	91,209	—	90,856
2403-1089 2403-1091		H8—11H	2,047	3,025	4,114	34,554	36,007	37,345	19,544	23,856	20,654	6,518	33	81,153	80,992	80,800
												8,282	—	85,928	—	85,575
												10,353	—	91,306	—	90,953
2403-1092		H7—9H	2,136	3,102	4,163	37,050	38,466	39,855	19,804	27,354	20,420	6,518	30	81,036	80,856	80,644
												8,282	—	85,834	—	85,442
												10,353	—	91,233	—	90,841
2403-1093		H8—11H	2,095	3,061	4,122	37,059	38,525	39,881	19,763	27,307	20,611	6,518	30	81,157	80,977	80,766
												8,282	—	85,942	—	85,551
												10,353	—	91,330	—	90,939
2403-1094 2403-1095	H7—9H	2,118	2,958	3,943	37,050	38,466	39,855	20,090	27,354	20,420	6,518	34	86,293	86,132	85,947	
											8,282	—	91,249	—	90,903	
											8,690	—	92,360	—	92,014	
2403-1096 2403-1097	H8—11H	2,078	2,918	3,903	37,050	38,466	39,855	20,050	27,354	20,420	6,518	34	86,421	86,260	86,075	
											8,282	—	91,362	—	91,016	
											8,690	—	92,471	—	92,125	
2403-1098	H7—9H	2,124	2,991	3,951	37,059	38,525	39,881	20,281	27,307	20,611	6,518	31	86,307	86,118	85,916	
											8,282	—	91,274	—	90,883	
											8,690	—	92,388	—	91,997	
2403-1099	H8—11H	2,084	2,951	3,911	37,059	38,525	39,881	20,241	27,307	20,611	6,518	31	86,436	86,247	86,044	
											8,282	—	91,389	—	90,997	
											8,690	—	92,500	—	92,108	

## Размеры в мм

Обозначение протяжки	D×t	Сочетание полей допус- ков D и e	x <sub>1</sub>	x <sub>2</sub>	x <sub>3</sub>	y <sub>1</sub>	y <sub>2</sub>	y <sub>3</sub>	x <sub>4</sub>	y <sub>4</sub>	R	d <sub>p</sub>	W	M		
														На буртике	На зубе номер W	На последнем калибрующем зубе
2403-1101 2403-1102	85×3,5	H7—9H	2,121	2,909	3,804				20,277			6,518	34	91,436	91,268	91,083
												8,282	—	96,579	—	96,226
												8,690	—	97,725	—	97,372
2403-1103 2403-1104		H8—11H	2,082	2,870	3,765	39,483	40,980	42,383	20,238	30,884	20,089	6,518	34	91,572	91,404	91,219
												8,282	—	96,698	—	96,345
												8,690	—	97,841	—	97,488
2403-1105		H7—9H	2,140	2,915	3,783				20,437			6,518	31	91,450	91,261	91,050
												8,282	—	96,605	—	96,205
												8,690	—	97,754	—	97,354
2403-1106	H8—11H	2,101	2,876	3,744	39,522	40,997	42,368	20,398	30,857	20,245	6,518	31	91,587	91,398	91,187	
											8,282	—	96,725	—	96,325	
											8,690	—	97,870	—	97,470	
2403-1107 2403-1108	90×3,5	H7—9H	2,157	3,109	4,188			23,495			6,518	33	95,942	95,788	95,596	
											8,282	—	100,744	—	100,398	
											10,353	—	106,178	—	105,832	
2403-1109 2403-1111		H8—11H	2,115	3,068	4,147	42,055	43,469	44,854	23,453	28,708	25,169	6,518	33	96,061	95,907	95,715
												8,282	—	100,853	—	100,507
												10,353	—	106,278	—	105,932
2403-1112 2403-1113		60×4	H7—9H	2,530	3,833	5,387			16,809			8,282	37	67,906	67,732	67,521
												10,353	—	73,073	—	72,688
												13,133	—	79,770	—	79,385
2403-1114 2403-1115	H8—11H		2,487	3,790	5,344	26,560	28,110	29,572	16,766	15,876	17,834	8,282	37	68,007	67,833	67,622
												10,353	—	73,164	—	72,779
												13,133	—	79,851	—	79,466

## Размеры в мм

Обозначение протяжки	$D \ m$	Сочетание полей допус- ков $D$ и $e$	$x_1$	$x_2$	$x_3$	$y_1$	$y_2$	$y_3$	$x_0$	$y_0$	$R$	$a_p$	$W$	M		
														На буртике	На зубе номер $W$	На последнем калибрующем зубе
2403-1116	60×4	H7—9H	2,512	3,847	5,367				16,855			8,282	35	67,912	67,722	67,498
												10,353	—	73,084	—	72,670
												13,133	—	79,787	—	79,373
2403-1117	60×4	H8—11H	2,469	3,804	5,323	26,536	28,130	29,566	16,812	15,883	17,867	8,282	35	68,014	67,823	67,599
												10,353	—	73,176	—	72,761
												13,133	—	79,869	—	79,454
2403-1118 2403-1119	65×4	H7—9H	2,447	3,536	4,797				17,365			8,282	38	73,772	73,598	73,393
												10,353	—	79,174	—	78,795
												12,423	—	84,360	—	83,981
2403-1121 2403-1122	65×4	H8—11H	2,406	3,495	4,756	29,148	30,737	32,200	17,324	20,093	17,451	8,282	38	73,882	73,708	73,503
												10,353	—	79,271	—	78,892
												12,423	—	84,448	—	84,069
2403-1123	65×4	H7—9H	2,435	3,495	4,779				17,373			8,282	35	73,786	73,603	73,379
												10,353	—	79,193	—	78,786
												12,423	—	84,383	—	83,976
2403-1124	65×4	H8—11H	2,394	3,454	4,739	29,128	30,690	32,193	17,332	20,129	17,440	8,282	35	73,896	73,713	73,489
												10,353	—	79,291	—	78,884
												12,423	—	84,471	—	84,064
2403-1125 2403-1126	70×4	H7—9H	2,387	3,558	4,901				18,751			8,282	37	78,982	78,800	78,587
												10,353	—	84,378	—	83,983
												13,133	—	91,326	—	90,931
2403-1127 2403-1128	70×4	H8—11H	2,346	3,516	4,859	31,520	33,183	34,719	18,709	21,250	19,320	8,282	37	79,093	78,911	78,698
												10,353	—	84,478	—	84,083
												13,133	—	91,414	—	91,019

## Размеры в мм

Обозначение протяжки	D m	Сочетание полей допус- ков D и e	x <sub>1</sub>	x <sub>2</sub>	x <sub>3</sub>	y <sub>1</sub>	y <sub>2</sub>	y <sub>3</sub>	x <sub>0</sub>	y <sub>0</sub>	R	d <sub>p</sub>	W	M		
														На буртике	На зубе номер W	На последнем калибрующем зубе
2403-1129 2403-1131	75×4	H7—9H	2,467	3,635	5,003	34,091	35,686	37,225	20,245	22,298	21,334	8,282	37	83,482	83,308	83,096
												10,353	—	88,844	—	88,458
												12,423	—	94,027	—	93,641
2403-1132 2403-1133	75×4	H8—11H	2,425	3,593	4,961	34,091	35,686	37,225	20,203	22,298	21,334	8,282	37	83,591	83,417	83,205
												10,353	—	88,942	—	88,566
												12,423	—	94,117	—	93,731
2403-1134 2403-1135	80×4	H7—9H	2,510	3,713	5,104	36,594	38,190	39,733	21,701	23,378	23,301	8,282	37	88,632	88,457	88,244
												10,353	—	93,989	—	93,601
												12,423	—	99,182	—	98,794
2403-1136 2403-1137	80×4	H8—11H	2,468	3,671	5,062	36,594	38,190	39,733	21,659	23,378	23,301	8,282	37	88,740	88,565	88,352
												10,353	—	94,088	—	93,700
												12,423	—	99,273	—	98,885
2403-1138 2403-1139	85×4	H7—9H	2,377	3,460	4,682	39,038	40,727	42,305	21,996	27,646	22,687	8,282	38	94,293	94,104	93,898
												10,353	—	99,853	—	99,458
												10,950	—	101,414	—	101,019
2403-1141 2403-1142	85×4	H8—11H	2,336	3,420	4,641	39,038	40,727	42,305	21,956	27,646	22,687	8,282	38	94,407	94,218	94,012
												10,353	—	99,956	—	99,561
												10,950	—	101,514	—	101,119
2403-1143 2403-1144	90×4	H7—9H	2,437	3,518	4,767	41,609	43,227	44,807	23,511	28,707	24,710	8,282	38	98,884	98,703	98,497
												10,353	—	104,404	—	104,017
												10,950	—	105,958	—	105,571
2403-1145 2403-1146	90×4	H8—11H	2,396	3,477	4,726	41,609	43,227	44,807	23,470	28,707	24,710	8,282	38	98,999	98,818	98,612
												10,353	—	104,508	—	104,121
												10,950	—	106,059	—	105,672

## Размеры в мм

Обозначение протяжки	D×t	Сочетание полей допус- ков D и e	x <sub>1</sub>	x <sub>2</sub>	x <sub>3</sub>	y <sub>1</sub>	y <sub>2</sub>	y <sub>3</sub>	x <sub>0</sub>	y <sub>0</sub>	R	d <sub>p</sub>	W	M		
														На буртике	На зубе номер W	На последнем калибрующем зубе
2403-1147	70×5	H7—9H	3,066	4,757	6,806	30,547	32,515	34,353	19,548	18,090	20,660	10,950	35	81,823	81,623	81,381
												13,133	—	87,215	—	86,773
												17,362	—	97,303	—	96,861
2403-1148	70×5	H8—11H	3,017	4,709	6,757	30,547	32,515	34,353	19,499	18,090	20,660	10,950	35	81,933	81,733	81,491
												13,133	—	87,316	—	86,874
												17,362	—	97,390	—	96,948
2403-1149	75×5	H7—9H	3,124	4,795	6,704	33,143	35,125	36,913	20,855	19,895	22,133	10,950	36	86,368	86,169	85,938
												13,133	—	91,778	—	91,348
												17,362	—	101,900	—	101,470
2403-1151	75×5	H8—11H	3,076	4,747	6,655	33,143	35,125	36,913	20,806	19,895	22,133	10,950	36	86,479	86,281	86,049
												13,133	—	91,881	—	91,451
												17,362	—	101,989	—	101,559
2403-1152	80×5	H7—9H	3,119	4,757	6,615	35,654	37,652	39,467	22,084	21,775	23,501	10,950	36	92,019	91,818	91,585
												13,133	—	97,493	—	97,059
												17,362	—	107,730	—	107,296
2403-1153	80×5	H8—11H	3,071	4,709	6,567	35,654	37,652	39,467	22,036	21,775	23,501	10,950	36	92,131	91,931	91,698
												13,133	—	97,596	—	97,163
												17,362	—	107,820	—	107,387
2403-1154	85×5	H7—9H	3,114	4,724	6,537	38,163	40,175	42,012	23,300	23,655	24,859	10,950	36	96,635	96,436	96,204
												13,133	—	102,128	—	101,697
												17,362	—	112,400	—	111,963



## Размеры в мм

Обозначение протяжки	$D \times t$	Сочетание полей допусков $D$ и $e$	$x_1$	$x_2$	$x_3$	$y_1$	$y_2$	$y_3$	$x_0$	$y_0$	$R$	$d_p$	$W$	M		
														На буртыке	На зубе номер $W$	На последнем калибрующем зубе
2403-1155	85×5	H8—11H	3,066	4,676	6,489	38,163	40,175	42,012	23,252	23,655	24,859	10,950	36	96,749	96,550	96,318
												13,133	—	102,233	—	101,802
												17,362	—	112,492	—	112,061
2403-1156	90×5	H7—9H	3,047	4,620	6,469	40,586	42,612	44,555	24,434	25,606	26,111	10,950	35	102,195	101,995	101,754
												13,133	—	107,741	—	107,300
												17,362	—	118,111	—	117,670
2403-1157	90×5	H8—11H	2,999	4,572	6,421	40,586	42,612	44,555	24,386	25,606	26,111	10,950	35	102,312	102,112	101,871
												13,133	—	107,849	—	107,408
												17,362	—	118,205	—	117,764

Примечания: 1.  $C$  — величина подъема заднего центра на длине  $L$  при шлифовании фасонным кругом боковых поверхностей фасочных и шлицевых зубьев.

2.  $O$  — ось протяжки.

3. Полный размер фаски  $F$  — на калибрующих зубьях.

4. Размер  $b$  относится к последнему фасочному зубу.

5. Размеры профиля (глубина и радиусы) зубьев с шагом  $t_2$  одинаковы с размерами профиля зубьев с шагом  $t$ .

6. Номер последнего зуба со стружкоделительной канавкой —  $j$ . Канавки на зубьях располагать в шахматном порядке.

7. Диаметры роликов  $d_p$  для контроля профиля соответствуют ГОСТ 2475—62 (диаметр 7 мм соответствует ГОСТ 6033—80).

8. После контроля профиля зубьев протяжки контрольный буртик сошлифовать до диаметра первого шлицевого зуба. При этом допускается увеличение ширины задней поверхности этого зуба.

9. Допускается изготовление протяжек без стружкоделительных канавок на фасочных зубьях.

## Размеры в мм

Обозначение проточки	2403-0961 2403-0962	2403-0963 2403-0964	2403-0965 2403-0966	2403-0967 2403-0968	2403-0969 2403-0971	2403-0972 2403-0973	2403-0974 2403-0975	2403-0976 2403-0977	2403-0978 2403-0979	2403-0981 2403-0982	2403-0983 2403-0984	2403-0985 2403-0986	
Сочетание полей допусков <i>D</i> и <i>e</i>	H7—9H	H8—11H	H7—9H	H8—11H	H7—9H	H8—11H	H7—9H	H8—11H	H7—9H	H8—11H	H7—9H	H8—11H	
<i>D</i> × <i>t</i>	45 × 3				48 × 3				50 × 3				
Номера и диаметры <i>D<sub>г</sub></i> зубьев шлицевых фасочных черновых и переходных	1	39,000	39,000	39,000	39,000	42,000	42,000	42,000	42,000	44,000	44,000	44,000	44,000
	2	39,120	39,120	39,130	39,130	42,120	42,120	42,130	42,130	44,120	44,120	44,160	44,160
	3	39,240	39,240	39,260	39,260	42,240	42,240	42,260	42,260	44,240	44,240	44,320	44,320
	4	39,360	39,360	39,390	39,390	42,360	42,360	42,390	42,390	44,360	44,360	44,480	44,480
	5	39,480	39,480	39,520	39,520	42,480	42,480	42,520	42,520	44,480	44,480	44,640	44,640
	6	39,600	39,600	39,650	39,650	42,600	42,600	42,650	42,650	44,600	44,600	44,800	44,800
	7	39,720	39,720	39,780	39,780	42,720	42,720	42,780	42,780	44,720	44,720	44,960	44,960
	8	39,840	39,840	39,910	39,910	42,840	42,840	42,910	42,910	44,840	44,840	45,120	45,120
	9	39,960	39,960	40,040	40,040	42,960	42,960	43,040	43,040	44,960	44,960	45,280	45,280
	10	40,080	40,080	40,170	40,170	43,080	43,080	43,170	43,170	45,080	45,080	45,240	45,240
	11	40,040	40,040	40,130	40,130	43,200	43,200	43,130	43,130	45,200	45,200	45,400	45,400
	12	40,160	40,160	40,260	40,260	43,160	43,160	43,260	43,260	45,160	45,160	45,560	45,560
	13	40,280	40,280	40,390	40,390	43,280	43,280	43,390	43,390	45,280	45,280	45,720	45,720
	14	40,400	40,400	40,520	40,520	43,400	43,400	43,520	43,520	45,400	45,400	45,880	45,880
	15	40,520	40,520	40,650	40,650	43,520	43,520	43,650	43,650	45,520	45,520	46,040	46,040
	16	40,640	40,640	40,780	40,780	43,640	43,640	43,780	43,780	45,640	45,640	46,200	46,200
	17	40,760	40,760	40,910	40,910	43,760	43,760	43,910	43,910	45,760	45,760	46,360	46,360
	18	40,880	40,880	41,040	41,040	43,880	43,880	44,040	44,040	45,880	45,880	46,520	46,520
	19	41,000	41,000	41,170	41,170	44,000	44,000	44,170	44,170	46,000	46,000	46,680	46,680
	20	41,120	41,120	41,300	41,300	44,120	44,120	44,300	44,300	46,120	46,120	46,840	46,840
	21	41,240	41,240	41,430	41,430	44,240	44,240	44,430	44,430	46,240	46,240	47,000	47,000
	22	41,360	41,360	41,560	41,560	44,360	44,360	44,560	44,560	46,360	46,360	47,160	47,160

Размеры в мм

Обозначение протяжки	2403-0961 2403-0962	2403-0963 2403-0964	2403-0965 2403-0966	2403-0967 2403-0968	2403-0969 2403-0971	2403-0972 2403-0973	2403-0974 2403-0975	2403-0976 2403-0977	2403-0978 2403-0979	2403-0981 2403-0982	2403-0983 2403-0984	2403-0985 2403-0986	
	H7-9H	H8-11H	H7-9H	H8-11H	H7-9H	H8-11H	H7-9H	H8-11H	H7-9H	H8-11H	H7-9H	H8-11H	
D×t	45×3				48×3				50×3				
Номера и диаметры D t зубьев шлицевых черновых и переходных	23	41,480	41,480	41,690	41,690	44,480	44,480	44,690	44,690	46,480	46,480	47,320	47,320
	24	41,600	41,600	41,820	41,820	44,600	44,600	44,820	44,820	46,600	46,600	47,480	47,480
	25	41,720	41,720	41,950	41,950	44,720	44,720	44,950	44,950	46,720	46,720	47,640	47,640
	26	41,840	41,840	42,080	42,080	44,840	44,840	45,080	45,080	46,840	46,840	47,800	47,800
	27	41,960	41,960	42,210	42,210	44,960	44,960	45,210	45,210	46,960	46,960	47,960	47,960
	28	42,080	42,080	42,340	42,340	45,080	45,080	45,340	45,340	47,080	47,080	48,120	48,120
	29	42,200	42,200	42,470	42,470	45,200	45,200	45,470	45,470	47,200	47,200	48,280	48,280
	30	42,320	42,320	42,600	42,600	45,320	45,320	45,600	45,600	47,320	47,320	48,440	48,440
	31	42,440	42,440	42,730	42,730	45,440	45,440	45,730	45,730	47,440	47,440	48,600	48,600
	32	42,560	42,560	42,860	42,860	45,560	45,560	45,860	45,860	47,560	47,560	48,760	48,760
	33	42,680	42,680	42,990	42,990	45,680	45,680	45,990	45,990	47,680	47,680	48,920	48,920
	34	42,800	42,800	43,120	43,120	45,800	45,800	46,120	46,120	47,800	47,800	49,080	49,080
	35	42,920	42,920	43,250	43,250	45,920	45,920	46,250	46,250	47,920	47,920	49,240	49,240
	36	43,040	43,040	43,380	43,380	46,040	46,040	46,380	46,380	48,040	48,040	49,400	49,400
	37	43,160	43,160	43,510	43,510	46,160	46,160	46,510	46,510	48,160	48,160	49,560	49,560
	38	43,280	43,280	43,640	43,640	46,280	46,280	46,640	46,640	48,280	48,280	49,720	49,720
	39	43,400	43,400	43,770	43,770	46,400	46,400	46,770	46,770	48,400	48,400	49,850	49,850
	40	43,520	43,520	43,900	43,900	46,520	46,520	46,900	46,900	48,520	48,520	49,930	49,930
	41	43,640	43,640	44,030	44,030	46,640	46,640	47,030	47,030	48,640	48,640	49,970	49,970
	42	43,760	43,760	44,160	44,160	46,760	46,760	47,160	47,160	48,760	48,760	49,990	50,000
	43	43,880	43,880	44,290	44,290	46,880	46,880	47,290	47,290	48,880	48,880	50,010	50,010
	44	44,000	44,000	44,420	44,420	47,000	47,000	47,420	47,420	49,000	49,000	50,025	50,039

Размеры в мм

Обозначение протяжки	2403-0961 2403-0962	2403-0963 2403-0964	2403-0965 2403-0966	2403-0967 2403-0968	2403-0969 2403-0971	2403-0972 2403-0973	2403-0974 2403-0975	2403-0976 2403-0977	2403-0978 2403-0979	2403-0981 2403-0982	2403-0983 2403-0984	2403-0985 2403-0986		
	Н7-9Н	Н8-11Н	Н7-9Н	Н8-11Н	Н7-9Н	Н8-11Н	Н7-9Н	Н8-11Н	Н7-9Н	Н8-11Н	Н7-9Н	Н8-11Н		
Сочетание полей допусков D к e														
D × t	45 × 3				48 × 3				50 × 3					
Номера и диаметры D <sub>t</sub> зубьев шлицевых	черновых и промежуточных	45	44,120	44,120	44,550	44,550	47,120	47,120	47,550	47,550	49,120	49,120	50,025	50,039
		46	44,240	44,240	44,680	44,680	47,240	47,240	47,680	47,680	49,240	49,240		
		47	44,360	44,360	44,810	44,810	47,360	47,360	47,810	47,810	49,360	49,360		
		48	44,480	44,480	44,890	44,890	47,480	47,480	47,890	47,890	49,480	49,480		
		49	44,600	44,600	44,940	44,940	47,600	47,600	47,940	47,940	49,600	49,600		
		50	44,720	44,720	44,970	44,970	47,720	47,720	47,970	47,970	49,720	49,720		
		51	44,840	44,840	44,990	44,990	47,840	47,840	47,990	48,000	49,840	49,840		
		52	44,930	44,930	45,010	45,020	47,930	47,930	48,010	48,020	49,930	49,930		
		53	44,970	44,970	45,025	45,039	47,970	47,970	48,025	48,039	49,970	49,970		
		54	44,990	45,000	45,025	45,039	47,990	48,000	48,025	48,039	49,990	50,000		
	55	45,010	45,020	48,010			48,020	50,010			50,020			
	56	45,025	45,039	48,025			48,039	50,025			50,039			
	57	45,025	45,039	48,025			48,039	50,025			50,039			
	58													
	59													
	60	45,025	45,039	—	—	48,025	48,039	—	—	50,025	50,039			
	61													
	62													
	калибрующих	60	45,025	45,039	—	—	48,025	48,039	—	—	50,025	50,039		
		61												
	62													

## Размеры в мм

Обозначение протяжки	2403-0987 2403-0988	2403-0989 2403-0991	2403-0992 2403-0993	2403-0994 2403-0995	2403-0996 2403-0997 2403-1001 2403-1002	2403-0998 2403-0999 2403-1003 2403-1004	2403-1005 2403-1006	2403-1007 2403-1008	2403-1009 2403-1011	2403-1012 2403-1013	2403-1014 2403-1015	2403-1016 2403-1017	
	Н7—9Н	Н8—11Н	Н7—9Н	Н8—11Н	Н7—9Н	Н8—11Н	Н7—9Н	Н8—11Н	Н7—9Н	Н8—11Н	Н7—9Н	Н8—11Н	
Сочетание полей допусков D и ε													
D×t	52×3				55×3		60×3				65×3		
Номера и диаметры D <sub>г</sub> зубьев шлицевых черновых и переходных фасочных	1	46,000	46,000	46,000	46,000	49,000	49,000	54,000	54,000	54,000	54,000	59,000	59,000
	2	46,120	46,120	46,160	46,160	49,140	49,140	54,140	54,140	54,140	54,140	59,140	59,140
	3	46,240	46,240	46,320	46,320	49,280	49,280	54,280	54,280	54,280	54,280	59,280	59,280
	4	46,360	46,360	46,480	46,480	49,420	49,420	54,420	54,420	54,420	54,420	59,420	59,420
	5	46,480	46,480	46,640	46,640	49,560	49,560	54,560	54,560	54,560	54,560	59,560	59,560
	6	46,600	46,600	46,800	46,800	49,700	49,700	54,700	54,700	54,700	54,700	59,700	59,700
	7	46,720	46,720	46,960	46,960	49,840	49,840	54,840	54,840	54,840	54,840	59,840	59,840
	8	46,840	46,840	47,120	47,120	49,980	49,980	54,980	54,980	54,980	54,980	59,980	59,980
	9	46,960	46,960	47,080	47,080	50,120	50,120	55,120	55,120	55,120	55,120	60,120	60,120
	10	47,080	47,080	47,240	47,240	50,080	50,080	55,080	55,080	55,260	55,260	60,080	60,080
	11	47,040	47,040	47,400	47,400	50,220	50,220	55,220	55,220	55,220	55,220	60,220	60,220
	12	47,160	47,160	47,560	47,560	50,360	50,360	55,360	55,360	55,360	55,360	60,360	60,360
	13	47,280	47,280	47,720	47,720	50,500	50,500	55,500	55,500	55,500	55,500	60,500	60,500
	14	47,400	47,400	47,880	47,880	50,640	50,640	55,640	55,640	55,640	55,640	60,640	60,640
	15	47,520	47,520	48,040	48,040	50,780	50,780	55,780	55,780	55,780	55,780	60,780	60,780
	16	47,640	47,640	48,200	48,200	50,920	50,920	55,920	55,920	55,920	55,920	60,920	60,920
	17	47,760	47,760	48,360	48,360	51,060	51,060	56,060	56,060	56,060	56,060	61,060	61,060
	18	47,880	47,880	48,520	48,520	51,200	51,200	56,200	56,200	56,200	56,200	61,200	61,200
	19	48,000	48,000	48,680	48,680	51,340	51,340	56,340	56,340	56,340	56,340	61,340	61,340
	20	48,120	48,120	48,840	48,840	51,480	51,480	56,480	56,480	56,480	56,480	61,480	61,480
	21	48,240	48,240	49,000	49,000	51,620	51,620	56,620	56,620	56,620	56,620	61,620	61,620
	22	48,360	48,360	49,160	49,160	51,760	51,760	56,760	56,760	56,760	56,760	61,760	61,760

Размеры в мм

Обозначение протяжки	2403-0987 2403-0988	2403-0989 2403-0991	2403-0992 2403-0993	2403-0994 2403-0995	2403-0996 2403-0997 2403-1001 2403-1002	2403-0998 2403-0999 2403-1003 2403-1004	2403-1005 2403-1006	2403-1007 2403-1008	2403-1009 2403-1011	2403-1012 2403-1013	2403-1014 2403-1015	2403-1016 2403-1017
	52×3				55×3		60×3				65×3	
Сочетание полей допусков D и e	H7-9H	H8-11H	H7-9H	H8-11H	H7-9H	H8-11H	H7-9H	H8-11H	H7-9H	H8-11H	H7-9H	H8-11H
D×m	52×3				55×3		60×3				65×3	
23	48,480	48,480	49,320	49,320	51,900	51,900	56,900	56,900	56,900	56,900	61,900	61,900
24	48,600	48,600	49,480	49,480	52,040	52,040	57,040	57,040	57,040	57,040	62,040	62,040
25	48,720	48,720	49,640	49,640	52,180	52,180	57,180	57,180	57,180	57,180	62,180	62,180
26	48,840	48,840	49,800	49,800	52,320	52,320	57,320	57,320	57,320	57,320	62,320	62,320
27	48,960	48,960	49,960	49,960	52,460	52,460	57,460	57,460	57,460	57,460	62,460	62,460
28	49,080	49,080	50,120	50,120	52,600	52,600	57,600	57,600	57,600	57,600	62,600	62,600
29	49,200	49,200	50,280	50,280	52,740	52,740	57,740	57,740	57,740	57,740	62,740	62,740
30	49,320	49,320	50,440	50,440	52,880	52,880	57,880	57,880	57,880	57,880	62,880	62,880
31	49,440	49,440	50,600	50,600	53,020	53,020	58,020	58,020	58,020	58,020	63,020	63,020
32	49,560	49,560	50,760	50,760	53,160	53,160	58,160	58,160	58,160	58,160	63,160	63,160
33	49,680	49,680	50,920	50,920	53,300	53,300	58,300	58,300	58,300	58,300	63,300	63,300
34	49,800	49,800	51,080	51,080	53,440	53,440	58,440	58,440	58,440	58,440	63,440	63,440
35	49,920	49,920	51,240	51,240	53,580	53,580	58,580	58,580	58,580	58,580	63,580	63,580
36	50,040	50,040	51,400	51,400	53,720	53,720	58,720	58,720	58,720	58,720	63,720	63,720
37	50,160	50,160	51,560	51,560	53,860	53,860	58,860	58,860	58,860	58,860	63,860	63,860
38	50,280	50,280	51,720	51,720	54,000	54,000	59,000	59,000	59,000	59,000	64,000	64,000
39	50,400	50,400	51,840	51,840	54,140	54,140	59,140	59,140	59,140	59,140	64,140	64,140
40	50,520	50,520	51,930	51,930	54,280	54,280	59,280	59,280	59,280	59,280	64,280	64,280
41	50,640	50,640	51,970	51,970	54,420	54,420	59,420	59,420	59,420	59,420	64,420	64,420
42	50,760	50,760	51,990	52,000	54,560	54,560	59,560	59,560	59,560	59,560	64,560	64,560
43	50,880	50,880	52,010	52,025	54,700	54,700	59,700	59,700	59,700	59,700	64,700	64,700
44	51,000	51,000	52,030	52,046	54,840	54,840	59,840	59,840	59,840	59,840	64,840	64,840

Номера и диаметры D<sub>i</sub> зубьев

шлицевых

черновых и переходных

Размеры в мм

Обозначение протяжки	2403-0987 2403-0988	2403-0989 2403-0991	2403-0992 2403-0993	2403-0994 2403-0995	2403-0996 2403-0997 2403-1001 2403-1002	2403-0998 2403-0999 2403-1003 2403-1004	2403-1005 2403-1006	2403-1007 2403-1008	2403-1009 2403-1011	2403-1012 2403-1013	2403-1014 2403-1015	2403-1016 2403-1017				
	52×3				55×3		60×3				65×3					
Сочетание полей допусков D и e	H7-9H	H8-11H	H7-9H	H8-11H	H7-9H	H8-11H	H7-9H	H8-11H	H7-9H	H8-11H	H7-9H	H8-11H				
D×t	52×3				55×3		60×3				65×3					
Номера и диаметры D <sub>t</sub> зубьев	Шлицевых ■ черновых и переходных	45	51,120	51,120	52,030	52,046	54,930	54,930	59,930	59,930	59,930	59,930	64,930	64,930		
		46	51,240	51,240			54,970	54,970	59,970	59,970	59,970	59,970	64,970	64,970		
		47	51,360	51,360			54,990	55,000	59,990	60,000	59,990	60,000	64,990	65,000		
		48	51,480	51,480			55,010	55,025	60,010	60,025	60,010	60,025	65,010	65,025		
		49	51,600	51,600			55,030	55,046	60,030	60,046	60,030	60,046	65,030	65,046		
		50	51,720	51,720			—	—	55,030	55,046	60,030	60,046	60,030	60,046	65,030	65,046
		51	51,840	51,840												
		52	51,930	51,930												
		53	51,970	51,970												
		54	51,990	52,000												
	55	52,010	52,025													
	56	52,030	52,046													
	■ калибрующих	57	52,030	52,046	—	—	—	—	—	—	—	—	—			
		58														
		59														
		60														
		61														
		62														

## Размеры в мм

Обозначение протяжки	2403-1018 2403-1019	2403 1021 2403-1022	2403-1023 2403-1024	2403-1025 2403-1026	2403-1027 2403-1028	2403-1029 2403-1031	2403-1032 2403-1033	2403-1034 2403-1035	2403 1036 2403 1037	2403-1038 2403 1039	2403 1041 2403-1042	2403-1043 2403 1044	
	Н7—9Н	Н8—11Н	Н7—9Н	Н8—11Н	Н7—9Н	Н8—11Н	Н7—9Н	Н8—11Н	Н7—9Н	Н8—11Н	Н7—9Н	Н8—11Н	
Сочетание полей допусков D и e													
D×t	65×3		70×3				75×3				80×3		
Номера и диаметры D <sub>1</sub> зубьев шлифовых черновых и переходных фасочных	1	59,000	59,000	64,000	64,000	64,000	64,000	69,000	69,000	69,000	69,000	74,000	74,000
	2	59,160	59,160	64,140	64,140	64,160	64,160	69,140	69,140	69,160	69,160	74,140	74,140
	3	59,320	59,320	64,280	64,280	64,320	64,320	69,280	69,280	69,320	69,320	74,280	74,280
	4	59,480	59,480	64,420	64,420	64,480	64,480	69,420	69,420	69,480	69,480	74,420	74,420
	5	59,640	59,640	64,560	64,560	64,640	64,640	69,560	69,560	69,640	69,640	74,560	74,560
	6	59,800	59,800	64,700	64,700	64,800	64,800	69,700	69,700	69,800	69,800	74,700	74,700
	7	59,960	59,960	64,840	64,840	64,960	64,960	69,840	69,840	69,960	69,960	74,840	74,840
	8	60,120	60,120	64,980	64,980	65,120	65,120	69,980	69,980	70,120	70,120	74,980	74,980
	9	60,080	60,080	65,120	65,120	65,280	65,280	70,120	70,120	70,080	70,080	75,120	75,120
	10	60,240	60,240	65,080	65,080	65,240	65,240	70,080	70,080	70,240	70,240	75,080	75,080
	11	60,400	60,400	65,220	65,220	65,400	65,400	70,220	70,220	70,400	70,400	75,220	75,220
	12	60,560	60,560	65,360	65,360	65,560	65,560	70,360	70,360	70,560	70,560	75,360	75,360
	13	60,720	60,720	65,500	65,500	65,720	65,720	70,500	70,500	70,720	70,720	75,500	75,500
	14	60,880	60,880	65,640	65,640	65,880	65,880	70,640	70,640	70,880	70,880	75,640	75,640
	15	61,040	61,040	65,780	65,780	66,040	66,040	70,780	70,780	71,040	71,040	75,780	75,780
	16	61,200	61,200	65,920	65,920	66,200	66,200	70,920	70,920	71,200	71,200	75,920	75,920
	17	61,360	61,360	66,060	66,060	66,360	66,360	71,060	71,060	71,360	71,360	76,060	76,060
	18	61,520	61,520	66,200	66,200	66,520	66,520	71,200	71,200	71,520	71,520	76,200	76,200
	19	61,680	61,680	66,340	66,340	66,680	66,680	71,340	71,340	71,680	71,680	76,340	76,340



## Размеры в мм

Обозначение протяжки	2403-1018 2403-1019	2403-1021 2403-1022	2403-1023 2403-1024	2403-1025 2403-1026	2403-1027 2403-1028	2403-1029 2403-1031	2403-1032 2403-1033	2403-1034 2403-1035	2403-1036 2403-1037	2403-1038 2403-1039	2403-1041 2403-1042	2403-1043 2403-1044	
	Н7—9Н	Н8—11Н	Н7—9Н	Н8—11Н	Н7—9Н	Н8—11Н	Н7—9Н	Н8—11Н	Н7—9Н	Н8—11Н	Н7—9Н	Н8—11Н	
Сочетание полей допусков D и e													
D×t	65×3		70×3				75×3				80×3		
Номера и диаметры D <sub>t</sub> зубьев шлицевых черновых и переходных	20	61,840	61,840	66,480	66,480	66,840	66,840	71,480	71,480	71,840	71,840	76,480	76,480
	21	62,000	62,000	66,620	66,620	67,000	67,000	71,620	71,620	72,000	72,000	76,620	76,620
	22	62,160	62,160	66,760	66,760	67,160	67,160	71,760	71,760	72,160	72,160	76,760	76,760
	23	62,320	62,320	66,900	66,900	67,320	67,320	71,900	71,900	72,320	72,320	76,900	76,900
	24	62,480	62,480	67,040	67,040	67,480	67,480	72,040	72,040	72,480	72,480	77,040	77,040
	25	62,640	62,640	67,180	67,180	67,640	67,640	72,180	72,180	72,640	72,640	77,180	77,180
	26	62,800	62,800	67,320	67,320	67,800	67,800	72,320	72,320	72,800	72,800	77,320	77,320
	27	62,960	62,960	67,460	67,460	67,960	67,960	72,460	72,460	72,960	72,960	77,460	77,460
	28	63,120	63,120	67,600	67,600	68,120	68,120	72,600	72,600	73,120	73,120	77,600	77,600
	29	63,280	63,280	67,740	67,740	68,280	68,280	72,740	72,740	73,280	73,280	77,740	77,740
	30	63,440	63,440	67,880	67,880	68,440	68,440	72,880	72,880	73,440	73,440	77,880	77,880
	31	63,600	63,600	68,020	68,020	68,600	68,600	73,020	73,020	73,600	73,600	78,020	78,020
	32	63,760	63,760	68,160	68,160	68,760	68,760	73,160	73,160	73,760	73,760	78,160	78,160
	33	63,920	63,920	68,300	68,300	68,920	68,920	73,300	73,300	73,920	73,920	78,300	78,300
	34	64,080	64,080	68,440	68,440	69,080	69,080	73,440	73,440	74,080	74,080	78,440	78,440
	35	64,240	64,240	68,580	68,580	69,240	69,240	73,580	73,580	74,240	74,240	78,580	78,580
	36	64,400	64,400	68,720	68,720	69,400	69,400	73,720	73,720	74,400	74,400	78,720	78,720
	37	64,560	64,560	68,860	68,860	69,560	69,560	73,860	73,860	74,560	74,560	78,860	78,860
	38	64,720	64,720	69,000	69,000	69,720	69,720	74,000	74,000	74,720	74,720	79,000	79,000
	39	64,850	64,850	69,140	69,140	69,850	69,850	74,140	75,140	74,850	74,850	79,140	79,140
40	64,930	64,930	69,280	69,280	69,930	69,930	74,280	74,280	74,930	74,930	79,280	79,280	

Размеры в мм

Обозначение протяжки	2403-1018 2403 1019	2403-1021 2403-1022	2403-1023 2403-1024	2403-1025 2403-1026	2403-1027 2403-1028	2403-1029 2403-1031	2403 1032 2403 1033	2403-1034 2403 1035	2403-1036 2403-1037	2403-1038 2403-1039	2403-1041 2403-1042	2403-1043 2403-1044	
Сочетание полей допусков <i>D и e</i>	H7-9H	H8-11H	H7-9H	H8-11H	H7-9H	H8-11H	H7-9H	H8-11H	H7-9H	H8-11H	H7-9H	H8-11H	
<i>D</i> × <i>t</i>	65×3		70×3				75×3				80×3		
Номера и диаметры <i>D<sub>i</sub></i> зубьев шлицевых калнбрующихся	41	64,970	64,970	69,420	69,420	69,970	69,970	74,420	74,420	74,970	74,970	79,420	79,420
	42	64,990	65,000	69,560	69,560	69,900	70,000	74,560	74,560	74,990	75,000	79,560	79,560
	43	65,010	65,025	69,700	69,700	70,010	70,025	74,700	74,700	75,010	75,025	79,700	79,700
	44	65,030	65,046	69,840	69,840	70,030	70,046	74,840	74,840	75,030	75,046	79,840	79,840
	45	65,030	65,046	69,930	69,930	70,030	70,046	74,930	74,930	75,030	75,046	79,930	79,930
	46			69,970	69,970			74,970	74,970			79,970	79,970
	47			69,990	70,000			74,990	75,000			79,990	80,000
	48			70,010	70,025			75,010	75,025			80,010	80,025
	49			70,030	70,046			75,030	75,046			80,030	80,046
	50	—	—	70,030	70,046	—	—	75,030	75,046	—	—	80,030	80,046
	51												
	52												
	53												
	54												
	55												

## Размеры в мм

Обозначение протяжки		2403-1045	2403-1046	2403-1047 2403-1048	2403-1049 2403-1051	2403-1052	2403-1053	2403-1054 2403-1055	2403-1056 2403-1057	2403-1058	2403-1059		
Сочетание полей допусков <i>D</i> и <i>e</i>		H7-9H	H8-11H	H7-9H	H8-11H	H7-9H	H8-11H	H7-9H	H8-11H	H7-9H	H8-11H		
<i>D</i> × <i>t</i>		80×3			85×3			90×3					
Номера и диаметры <i>D<sub>i</sub></i> зубьев	фасочных	1	74,000	74,000	79,000	79,000	79,000	79,000	84,000	84,000	84,000	84,000	
		2	74,150	74,150	79,140	79,140	79,150	79,150	84,140	84,140	84,130	84,130	
		3	74,300	74,300	79,280	79,280	79,300	79,300	84,280	84,280	84,260	84,260	
		4	74,450	74,450	79,420	79,420	79,450	79,450	84,420	84,420	84,390	84,390	
		5	74,600	74,600	79,560	79,560	79,600	79,600	84,560	84,560	84,520	84,520	
		6	74,750	74,750	79,700	79,700	79,750	79,750	84,700	84,700	84,650	84,650	
		7	74,900	74,900	79,840	79,840	79,900	79,900	84,840	84,840	84,780	84,780	
		8	75,050	75,050	79,980	79,980	80,050	80,050	84,980	84,980	84,910	84,910	
		9	75,200	75,200	80,120	80,120	80,200	80,200	85,120	85,120	85,040	85,040	
	шлицевых	черновых и переходных	10	75,160	75,160	80,080	80,080	80,160	80,160	85,080	85,080	85,170	85,170
			11	75,310	75,310	80,220	80,220	80,320	80,320	85,220	85,220	85,130	85,130
			12	75,460	75,460	80,360	80,360	80,480	80,480	85,360	85,360	85,280	85,280
			13	75,610	75,610	80,500	80,500	80,640	80,640	85,500	85,500	85,430	85,430
			14	75,760	75,760	80,640	80,640	80,800	80,800	85,640	85,640	85,580	85,580
			15	75,910	75,910	80,780	80,780	80,960	80,960	85,780	85,780	85,730	85,730
			16	76,060	76,060	80,920	80,920	81,120	81,120	85,920	85,920	85,880	85,880
			17	76,210	76,210	81,060	81,060	81,280	81,280	86,060	86,060	86,030	86,030
			18	76,360	76,360	81,200	81,200	81,440	81,440	86,200	86,200	86,180	86,180

## Размеры в мм

Обозначение протяжки		2403-1045	2403-1046	2403-1047 2403-1048	2403-1049 2403-1051	2403-1052	2403-1053	2403-1054 2403-1055	2403-1056 2403-1057	2403-1058	2403-1059		
Сочетание полей допусков <i>D</i> и <i>e</i>		H7—9H	H8—11H	H7—9H	H8—11H	H7—9H	H8—11H	H7—9H	H8—11H	H7—9H	H8—11H		
<i>D</i> × <i>t</i>		80×3			85×3			90×3					
Номера и диаметры <i>D</i> , зубьев	Шлицевых	черновых и переходных	19	76,510	76,510	81,340	81,340	81,600	81,600	86,340	86,340	86,330	86,330
			20	76,660	76,660	81,480	81,480	81,760	81,760	86,480	86,480	86,480	86,480
			21	76,810	76,810	81,620	81,620	81,920	81,920	86,620	86,620	86,630	86,630
			22	76,960	76,960	81,760	81,760	82,080	82,080	86,760	86,760	86,780	86,780
			23	77,110	77,110	81,900	81,900	82,240	82,240	86,900	86,900	86,930	86,930
			24	77,260	77,260	82,040	82,040	82,400	82,400	87,040	87,040	87,080	87,080
			25	77,410	77,410	82,180	82,180	82,560	82,560	87,180	87,180	87,230	87,230
			26	77,560	77,560	82,320	82,320	82,720	82,720	87,320	87,320	87,380	87,380
			27	77,710	77,710	82,460	82,460	82,880	82,880	87,460	87,460	87,530	87,530
			28	77,860	77,860	82,600	82,600	83,040	83,040	87,600	87,600	87,680	87,680
			29	78,010	78,010	82,740	82,740	83,200	83,200	87,740	87,740	87,830	87,830
			30	78,160	78,160	82,880	82,880	83,360	83,360	87,880	87,880	87,980	87,980
			31	78,310	78,310	83,020	83,020	83,520	83,520	88,020	88,020	88,130	88,130
			32	78,460	78,460	83,160	83,160	83,680	83,680	88,160	88,160	88,280	88,280
			33	78,610	78,610	83,300	83,300	83,840	83,840	88,300	88,300	88,430	88,430
			34	78,760	78,760	83,440	83,440	84,000	84,000	88,440	88,440	88,580	88,580
			35	78,910	78,910	83,580	83,580	84,160	84,160	88,580	88,580	88,730	88,730
36	79,060	79,060	83,720	83,720	84,320	84,320	88,720	88,720	88,880	88,880			
37	79,210	79,210	83,860	83,860	84,480	84,480	88,860	88,860	89,030	89,030			

Размеры в мм

Обозначение протяжки		2403-1045	2403-1046	2403-1047 2403-1048	2403-1049 2403-1051	2403-1052	2403-1053	2403-1054 2403-1055	2403-1056 2403-1057	2403-1058	2403-1059		
Сочетание полей допусков D и e		H7-9H	H8-11H	H7-9H	H8-11H	H7-9H	H8-11H	H7-9H	H8-11H	H7-9H	H8-11H		
D×t		80×3		85×3				90×3					
Номера и диаметры D и зубьев	шлицевых	черновых и переходных	38	79,360	79,360	84,000	84,000	84,640	84,640	89,000	89,000	89,180	89,180
			39	79,510	79,510	84,140	84,140	84,800	84,800	89,140	89,140	89,330	89,330
			40	79,660	79,660	84,280	84,280	84,900	84,900	89,280	89,280	89,480	89,480
			41	79,810	79,810	84,420	84,420	84,950	84,950	89,420	89,420	89,630	89,630
			42	79,890	79,890	84,560	84,560	84,980	84,980	89,560	89,560	89,780	89,780
			43	79,940	79,940	84,700	84,700	85,000	84,010	89,700	89,700	89,890	89,890
		чистовых	44	79,970	79,970	84,840	84,840	85,020	85,035	89,840	89,840	89,950	89,950
			45	79,990	80,000	84,940	84,940	85,035	85,054	89,940	89,940	89,980	89,980
			46	80,010	80,025	84,980	84,980	85,035	85,054	89,980	89,980	90,000	90,010
			47	80,030	80,046	85,000	85,010			90,000	90,010	90,020	90,035
		калибрующих	48	80,030	80,046	85,020	85,035	85,035	85,054	90,020	90,035	90,035	90,054
			49			85,035	85,054			90,035	90,054		
			50	80,030	80,046	85,035	85,054	85,035	85,054	90,035	90,054	90,035	90,054
			51										
			52										
			53	85,035	85,054	85,035	85,054	85,035	85,054	90,035	90,054	90,035	90,054
		54											
55	—	—	—	—	—	—	—	—	—	—	—		

Размеры в мм

Обозначение протяжки	2403-1061 2403-1062 2403-1065	2403-1063 2403-1064 2403-1066	2403-1067 2403-1068	2403-1069 2403-1071	2403-1072	2403-1073	2403-1074 2403-1075	2403-1076 2403-1077	2403-1078	2403-1079	2403-1081 2403-1082	2403-1083 2403-1084	
	Н7-9Н	Н8-11Н	Н7-9Н	Н8-11Н	Н7-9Н	Н8-11Н	Н7-9Н	Н8-11Н	Н7-9Н	Н8-11Н	Н7-9Н	Н8-11Н	
$D \times m$	55×3,5		60×3,5				65×3,5				70×3,5		
Номера и диаметры $D_i$ зубьев шлицевых фасочных черновых и переходных	1	48,000	48,000	53,000	53,000	53,000	53,000	58,000	58,000	58,000	58,000	63,000	63,000
	2	48,140	48,140	53,140	53,140	53,140	53,140	58,140	58,140	58,160	58,160	63,140	63,140
	3	48,280	48,280	53,280	53,280	53,280	53,280	58,280	58,280	58,320	58,320	63,280	63,280
	4	48,420	48,420	53,420	53,420	53,420	53,420	58,420	58,420	58,480	58,480	63,420	63,420
	5	48,560	48,560	53,560	53,560	53,560	53,560	58,560	58,560	58,640	58,640	63,560	63,560
	6	48,700	48,700	53,700	53,700	53,700	53,700	58,700	58,700	58,800	58,800	63,700	63,700
	7	48,840	48,840	53,840	53,840	53,840	53,840	58,840	58,840	58,960	58,960	63,840	63,840
	8	48,980	48,980	53,980	53,980	53,980	53,980	58,980	58,980	59,120	59,120	63,980	63,980
	9	49,120	49,120	54,120	54,120	54,120	54,120	59,120	59,120	59,280	59,280	64,120	64,120
	10	49,260	49,260	54,080	54,080	54,260	54,260	59,260	59,260	59,440	59,440	64,260	64,260
	11	49,220	<b>49,220</b>	54,220	54,220	54,220	54,220	59,220	59,220	59,400	59,400	64,220	64,220
	12	49,360	49,360	54,360	54,360	54,360	54,360	59,360	59,360	59,560	59,560	64,360	64,360
	13	49,500	49,500	54,500	54,500	54,500	54,500	59,500	59,500	59,720	59,720	64,500	64,500
	14	49,640	49,640	54,640	54,640	54,640	54,640	59,640	59,640	59,880	59,880	64,640	64,640
	15	49,780	49,780	54,780	54,780	54,780	54,780	59,780	59,780	60,040	60,040	64,780	64,780
	16	49,920	49,920	54,920	54,920	54,920	54,920	59,920	59,920	60,200	60,200	64,920	64,920
	17	50,060	50,060	55,060	55,060	55,060	55,060	60,060	60,060	60,360	60,360	65,060	65,060
	18	50,200	50,200	55,200	55,200	55,200	55,200	60,200	60,200	60,520	60,520	65,200	65,200
	19	50,340	50,340	55,340	55,340	55,340	55,340	60,340	60,340	60,680	60,680	65,340	65,340
	20	50,480	50,480	55,480	55,480	55,480	55,480	60,480	60,480	60,840	60,840	<b>65,480</b>	65,480
	21	50,620	50,620	55,620	55,620	55,620	55,620	60,620	60,620	61,000	61,000	65,620	65,620
	22	50,760	50,760	55,760	55,760	55,760	55,760	60,760	60,760	61,160	61,160	65,760	65,760

## Размеры в мм

Обозначение протяжки	2403-1061 2403-1062 2403-1065	2403-1063 2403-1064 2403-1066	2403-1067 2403-1068	2403-1069 2403-1071	2403-1072	2403-1073	2403-1074 2403-1075	2403-1076 2403-1077	2403-1078	2403-1079	2403-1081 2403-1082	2403-1083 2403-1084
	Н7-9Н	Н8-11Н	Н7-9Н	Н8-11Н	Н7-9Н	Н8-11Н	Н7-9Н	Н8-11Н	Н7-9Н	Н8-11Н	Н7-9Н	Н8-11Н
Сочетание полей допус- ков D и e												
D×m	55×3,5			60×3,5			65×3,5			70×3,5		
23	50,900	50,900	55,900	55,900	55,900	55,900	60,900	60,900	61,320	61,320	65,900	65,900
24	51,040	51,040	56,040	56,040	56,040	56,040	61,040	61,040	61,480	61,480	66,040	66,040
25	51,180	51,180	56,180	56,180	56,180	56,180	61,180	61,180	61,640	61,640	66,180	66,180
26	51,320	51,320	56,320	56,320	56,320	56,320	61,320	61,320	61,800	61,800	66,320	66,320
27	51,460	51,460	56,460	56,460	56,460	56,460	61,460	61,460	61,960	61,960	66,460	66,460
28	51,600	51,600	56,600	56,600	56,600	56,600	61,600	61,600	62,120	62,120	66,600	66,600
29	51,740	51,740	56,740	56,740	56,740	56,740	61,740	61,740	62,280	62,280	66,740	66,740
30	51,880	51,880	56,880	56,880	56,880	56,880	61,880	61,880	62,440	62,440	66,880	66,880
31	52,020	52,020	57,020	57,020	57,020	57,020	62,020	62,020	62,600	62,600	67,020	67,020
32	52,160	52,160	57,160	57,160	57,160	57,160	62,160	62,160	62,760	62,760	67,160	67,160
33	52,300	52,300	57,300	57,300	57,300	57,300	62,300	62,300	62,920	62,920	67,300	67,300
34	52,440	52,440	57,440	57,440	57,440	57,440	62,440	62,440	63,080	63,080	67,440	67,440
35	52,580	52,580	57,580	57,580	57,580	57,580	62,580	62,580	63,240	63,240	67,580	67,580
36	52,720	52,720	57,720	57,720	57,720	57,720	62,720	62,720	63,400	63,400	67,720	67,720
37	52,860	52,860	57,860	57,860	57,860	57,860	62,860	62,860	63,560	63,560	67,860	67,860
38	53,000	53,000	58,000	58,000	58,000	58,000	63,000	63,000	63,720	63,720	68,000	68,000
39	53,140	53,140	58,140	58,140	58,140	58,140	63,140	63,140	63,880	63,880	68,140	68,140
40	53,280	53,280	58,280	58,280	58,280	58,280	63,280	63,280	64,040	64,040	68,280	68,280
41	53,420	53,420	58,420	58,420	58,420	58,420	63,420	63,420	64,200	64,200	68,420	68,420
42	53,560	<b>53,560</b>	58,560	58,560	58,560	58,560	63,560	63,560	64,360	64,360	68,560	68,560
43	53,700	53,700	58,700	58,700	58,700	58,700	63,700	63,700	64,520	64,520	68,700	68,700
44	53,840	53,840	58,840	58,840	58,840	58,840	63,840	63,840	64,680	64,680	68,840	68,840

Номера и диаметры D и зубьев

шлицевых

черновых и переходных

Размеры в мм

Обозначение протяжки	2403-1061 2403-1062 2403-1065	2403-1063 2403-1064 2403-1066	2403-1067 2403-1068	2403-1069 2403-1071	2403-1072	2403-1073	2403-1074 2403-1075	2403-1076 2403-1077	2403-1078	2403-1079	2403-1081 2403-1082	2403-1083 2403-1084		
	Н7—9Н	Н8—11Н	Н7—9Н	Н8—11Н	Н7—9Н	Н8—11Н	Н7—9Н	Н8—11Н	Н7—9Н	Н8—11Н	Н7—9Н	Н8—11Н		
D×t	55×3,5		60×3,5				65×3,5				70×3,5			
черновых и переходных	45	53,980	53,980	58,980	58,980	58,980	58,980	63,980	63,980	64,840	64,840	68,980	68,980	
	46	54,120	54,120	59,120	59,120	59,120	59,120	64,120	64,120	64,930	64,930	69,120	69,120	
	47	54,260	54,260	59,260	59,260	59,260	59,260	64,260	64,260	64,970	64,970	69,260	69,260	
	48	54,400	54,400	59,400	59,400	59,400	59,400	64,400	64,400	64,990	65,000	69,400	69,400	
	49	54,540	54,540	59,540	59,540	59,540	59,540	64,540	64,540	65,010	65,025	69,540	69,540	
	50	54,680	54,680	59,680	59,680	59,680	59,680	64,680	64,680	65,030	65,046	69,680	69,680	
	51	54,820	54,820	59,820	59,820	59,820	59,820	64,820	64,820	65,030	65,046	69,820	69,820	
	52	54,890	54,890	59,890	59,890	59,890	59,890	64,890	64,890			69,890	69,890	
	53	54,940	54,940	59,940	59,940	59,940	59,940	64,940	64,940			69,940	69,940	
	чистовых	54	54,970	54,970	59,970	59,970	59,970	59,970	64,970	64,970	65,030	65,046	69,970	69,970
		55	54,990	55,000	59,990	60,000	59,990	60,000	64,990	65,000			69,990	70,000
		56	55,010	55,025	60,010	60,025	60,010	60,025	65,010	65,025			70,010	70,025
		57	55,030	55,046	60,030	60,046	60,030	60,046	65,030	65,046			70,030	70,046
калибрующих	58													
	59													
	60													
	61	55,030	55,046	60,030	60,046	60,030	60,046	65,030	65,046	—	—	70,030	70,046	
	62													
	63													

Номера и диаметры D t зубьев

шлицевых

чистовых

калибрующих



Размеры в мм

Обозначение протяжки	2403-1085	2403-1086	2403-1087 2403-1088	2403-1089 2403-1091	2403-1092	2403-1093	2403-1094 2403-1095	2403-1096 2403-1097	2403-1098	2403-1099	2403-1101 2403-1102	2403-1103 2403-1104	
	Н7—9Н	Н8—11Н	Н7—9Н	Н8—11Н	Н7—9Н	Н8—11Н	Н7—9Н	Н8—11Н	Н7—9Н	Н8—11Н	Н7—9Н	Н8—11Н	
$D \times t$	70×3,5		75×3,5				80×3,5				85×3,5		
Номера и диаметры $D_t$ зубьев шлицевых — фасочных — черновых и переходных	1	63,000	63,000	68,000	68,000	68,000	68,000	73,000	73,000	73,000	73,000	78,000	78,000
	2	63,160	63,160	68,140	68,140	68,160	68,160	73,140	73,140	73,160	73,160	78,140	78,140
	3	63,320	63,320	68,280	68,280	68,320	68,320	73,280	73,280	73,320	73,320	78,280	78,280
	4	63,480	63,480	68,420	68,420	68,480	68,480	73,420	73,420	73,480	73,480	78,420	78,420
	5	63,640	63,640	68,560	68,560	68,640	68,640	73,560	73,560	73,640	73,640	78,560	78,560
	6	63,800	63,800	68,700	68,700	68,800	68,800	73,700	73,700	73,800	73,800	78,700	78,700
	7	63,960	63,960	68,840	68,840	68,960	68,960	73,840	73,840	73,960	73,960	78,840	78,840
	8	64,120	64,120	68,980	68,980	69,120	69,120	73,980	73,980	74,120	74,120	78,980	78,980
	9	64,280	64,280	69,120	69,120	69,280	69,280	74,120	74,120	74,280	74,280	79,120	79,120
	10	64,440	64,440	69,080	69,080	69,240	69,240	74,260	74,260	74,240	74,240	79,080	79,080
	11	64,400	64,400	69,220	69,220	69,400	69,400	74,220	74,220	74,400	74,400	79,220	79,220
	12	64,560	64,560	69,360	69,360	69,560	69,560	74,360	74,360	74,560	74,560	79,360	79,360
	13	64,720	64,720	69,500	69,500	69,720	69,720	74,500	74,500	74,720	74,720	79,500	79,500
	14	64,880	64,880	69,640	69,640	69,880	69,880	74,640	74,640	74,880	74,880	79,640	79,640
	15	65,040	65,040	69,780	69,780	70,040	70,040	74,780	74,780	75,040	75,040	79,780	79,780
	16	65,200	65,200	69,920	69,920	70,200	70,200	74,920	74,920	75,200	75,200	79,920	79,920
	17	65,360	65,360	70,060	70,060	70,360	70,360	75,060	75,060	75,360	75,360	80,060	80,060
	18	65,520	65,520	70,200	70,200	70,520	70,520	75,200	75,200	75,520	75,520	80,200	80,200
	19	65,680	65,680	70,340	70,340	70,680	70,680	75,340	75,340	75,680	75,680	80,340	80,340
	20	65,840	65,840	70,480	70,480	70,840	70,840	75,480	75,480	75,840	75,840	80,480	80,480
	21	66,000	66,000	70,620	70,620	71,000	71,000	75,620	75,620	76,000	76,000	80,620	80,620
	22	66,160	66,160	70,760	70,760	71,160	71,160	75,760	75,760	76,160	76,160	80,760	80,760

## Размеры в мм

Обозначение протяжки	2403-1085	2403-1086	2403-1087 2403-1088	2403-1089 2403-1091	2403-1092	2403-1093	2403-1094 2403-1095	2403-1096 2403-1097	2403-1098	2403-1099	2403-1101 2403-1102	2403-1103 2403-1104	
	Н7-9Н	Н8-11Н	Н7-9Н	Н8-11Н	Н7-9Н	Н8-11Н	Н7-9Н	Н8-11Н	Н7-9Н	Н8-11Н	Н7-9Н	Н8-11Н	
$D \times t$	70×3,5		75×3,5				80×3,5				85×3,5		
Номера и диаметры $D_i$ зубьев шлицевых черновых и переходных	23	66,320	66,320	70,900	70,900	71,320	71,320	75,900	75,900	76,320	76,320	80,900	80,900
	24	66,480	66,480	71,040	71,040	71,480	71,480	76,040	76,040	76,480	76,480	81,040	81,040
	25	66,640	66,640	71,180	71,180	71,640	71,640	76,180	76,180	76,640	76,640	81,180	81,180
	26	66,800	66,800	71,320	71,320	71,800	71,800	76,320	76,320	76,800	76,800	81,320	81,320
	27	66,960	66,960	71,460	71,460	71,960	71,960	76,460	76,460	76,960	76,960	81,460	81,460
	28	67,120	67,120	71,600	71,600	72,120	72,120	76,600	76,600	77,120	77,120	81,600	81,600
	29	67,280	67,280	71,740	71,740	72,280	72,280	76,740	76,740	77,280	77,280	81,740	81,740
	30	67,440	67,440	71,880	71,880	72,440	72,440	76,880	76,880	77,440	77,440	81,880	81,880
	31	67,600	67,600	72,020	72,020	72,600	72,600	77,020	77,020	77,600	77,600	82,020	82,020
	32	67,760	67,760	72,160	72,160	72,760	72,760	77,160	77,160	77,760	77,760	82,160	82,160
	33	67,920	67,920	72,300	72,300	72,920	72,920	77,300	77,300	77,920	77,920	82,300	82,300
	34	68,080	68,080	72,440	72,440	73,080	73,080	77,440	77,440	78,080	78,080	82,440	82,440
	35	68,240	68,240	72,580	72,580	73,240	73,240	77,580	77,580	78,240	78,240	82,580	82,580
	36	68,400	68,400	72,720	72,720	73,400	73,400	77,720	77,720	78,400	78,400	82,720	82,720
	37	68,560	68,560	72,860	72,860	73,560	73,560	77,860	77,860	78,560	78,560	82,860	82,860
	38	68,720	68,720	73,000	73,000	73,720	73,720	78,000	78,000	78,720	78,720	83,000	83,000
	39	68,880	68,880	73,140	73,140	73,880	73,880	78,140	78,140	78,880	78,880	83,140	83,140
	40	69,040	69,040	73,280	73,280	74,040	74,040	78,280	78,280	79,040	79,040	83,280	83,280
	41	69,200	69,200	73,420	73,420	74,200	74,200	78,420	78,420	79,200	79,200	83,420	83,420
	42	69,360	69,360	73,560	73,560	74,360	74,360	78,560	78,560	79,360	79,360	83,560	83,560
	43	69,520	69,520	73,700	73,700	74,520	74,520	78,700	78,700	79,520	79,520	83,700	83,700
	44	69,680	69,680	73,840	73,840	74,680	74,680	78,840	78,840	79,680	79,680	83,840	83,840

Размеры в мм

Обозначение протяжки	2403-1085	2403-1086	2403-1087 2403-1088	2403-1089 2403-1091	2403-1092	2403-1093	2403-1094 2403-1095	2403-1096 2403-1097	2403-1098	2403-1099	2403-1101 2403-1102	2403-1103 2403-1104	
	H7-9H	H8-11H	H7-9H	H8-11H	H7-9H	H8-11H	H7-9H	H8-11H	H7-9H	H8-11H	H7-9H	H8-11H	
D×t	70×3,5		75×3,5				80×3,5				85×3,5		
Номера и диаметры D <sub>t</sub> зубьев шлицевых калибрующих	45	69,840	69,840	73,980	73,980	74,840	74,840	78,980	78,980	79,840	79,840	83,980	83,980
	46	69,930	69,930	74,120	74,120	74,930	74,930	79,120	79,120	79,930	79,930	84,120	84,120
	47	69,970	69,970	74,260	74,260	74,970	74,970	79,260	79,260	79,970	79,970	84,260	84,260
	48	69,990	70,000	74,400	74,400	74,990	75,000	79,400	79,400	79,990	80,000	84,400	84,400
	49	70,010	70,025	74,540	74,540	75,010	75,025	79,540	79,540	80,010	80,025	84,540	84,540
	50	70,030	70,046	74,680	74,680	75,030	75,046	79,680	79,680	80,030	80,046	84,680	84,680
	51	70,030	70,046	74,820	74,820	75,030	75,046	79,820	79,820	80,030	80,046	84,820	84,820
	52			74,890	74,890			79,890	79,890			84,890	84,890
	53			74,940	74,940			79,940	79,940			84,950	84,950
	54			74,970	74,970			79,970	79,970			84,980	84,980
	55			74,990	75,000			79,990	80,000			85,000	85,010
	56	75,010	75,025	80,010	80,025	85,020	85,035						
	57	75,030	75,046	80,030	80,046	85,035	85,054						
58	—	—	75,030	75,046	—	—	80,030	80,046	—	—	85,035	85,054	
59													
60													
61													
62													
63													

## Размеры в мм

Обозначение протяжки	2403-1105	2403-1106	2403-1107 2403-1108	2403-1109 2403-1111	2403-1112 2403-1113	2403-1114 2403-1115	2403-1116	2403-1117	2403-1118 2403-1119	2403-1121 2403-1122	2403-1123	2403-1124	
	Н7—9Н	Н8—11Н	Н7—9Н	Н8—11Н	Н7—9Н	Н8—11Н	Н7—9Н	Н8—11Н	Н7—9Н	Н8—11Н	Н7—9Н	Н8—11Н	
$D \times t$	85×3,5		90×3,5		60×4			65×4					
Номера и диаметры $D_t$ зубьев шлицевых фасочных черновых и переходных	1	78,000	78,000	83,000	83,000	52,000	52,000	52,000	52,000	57,000	57,000	57,000	57,000
	2	78,150	78,150	83,140	83,140	52,140	52,140	52,150	52,150	57,140	57,140	57,150	57,150
	3	78,300	78,300	83,280	83,280	52,280	52,280	52,300	52,300	57,280	57,280	57,300	57,300
	4	78,450	78,450	83,420	83,420	52,420	52,420	52,450	52,450	57,420	57,420	57,450	57,450
	5	78,600	78,600	83,560	83,560	52,560	52,560	52,600	52,600	57,560	57,560	57,600	57,600
	6	78,750	78,750	83,700	83,700	52,700	52,700	52,750	52,750	57,700	57,700	57,750	57,750
	7	78,900	78,900	83,840	83,840	52,840	52,840	52,900	52,900	57,840	57,840	57,900	57,900
	8	79,050	79,050	83,980	83,980	52,980	52,980	53,050	53,050	57,980	57,980	58,050	58,050
	9	79,200	79,200	84,120	84,120	53,120	53,120	53,200	53,200	58,120	58,120	58,200	58,200
	10	79,160	79,160	84,260	84,260	53,260	53,260	53,350	53,350	58,260	58,260	58,350	58,350
	11	79,320	79,320	84,220	84,220	53,400	53,400	53,310	53,310	58,400	58,400	58,500	58,500
	12	79,480	79,480	84,360	84,360	53,360	53,360	53,460	53,460	58,540	58,540	58,460	58,460
	13	79,640	79,640	84,500	84,500	53,500	53,500	53,610	53,610	58,500	58,500	58,610	58,610
	14	79,800	79,800	84,640	84,640	53,640	53,640	53,760	53,760	58,640	58,640	58,760	58,760
	15	79,960	79,960	84,780	84,780	53,780	53,780	53,910	53,910	58,780	58,780	58,910	58,910
	16	80,120	80,120	84,920	84,920	53,920	53,920	54,060	54,060	58,920	58,920	59,060	59,060
	17	80,280	80,280	85,060	85,060	54,060	54,060	54,210	54,210	59,060	59,060	59,210	59,210
	18	80,440	80,440	85,200	85,200	54,200	54,200	54,360	54,360	59,200	59,200	59,360	59,360
	19	80,600	80,600	85,340	85,340	54,340	54,340	54,510	54,510	59,340	59,340	59,510	59,510
	20	80,760	80,760	85,480	85,480	54,480	54,480	54,660	54,660	59,480	59,480	59,660	59,660
	21	80,920	80,920	85,620	85,620	54,620	54,620	54,810	54,810	59,620	59,620	59,810	59,810
	22	81,080	81,080	85,760	85,760	54,760	54,760	54,960	54,960	59,760	59,760	59,960	59,960
	23	81,240	81,240	85,900	85,900	54,900	54,900	55,110	55,110	59,900	59,900	60,110	60,110
	24	81,400	81,400	86,040	86,040	55,040	55,040	55,260	55,260	60,040	60,040	60,260	60,260

## Размеры в мм

Обозначение протяжки	2403-1105	2403-1106	2403-1107 2403-1108	2403-1109 2403-1111	2403-1112 2403-1113	2403-1114 2403-1115	2403-1116	2403-1117	2403-1118 2403-1119	2403-1121 2403-1122	2403 1123	2403-1124
	Н7-9Н	Н8-11Н	Н7-9Н	Н8-11Н	Н7-9Н	Н8-11Н	Н7-9Н	Н8-11Н	Н7-9Н	Н8-11Н	Н7-9Н	Н8-11Н
$D \times t$	85×3,5		90×3,5		60×4			65×4				
25	81,560	81,560	86,180	86,180	55,180	55,180	55,410	55,410	60,180	60,180	60,410	60,410
26	81,720	81,720	86,320	86,320	55,320	55,320	55,560	55,560	60,320	60,320	60,560	60,560
27	81,880	81,880	86,460	86,460	55,460	55,460	55,710	55,710	60,460	60,460	60,710	60,710
28	82,040	82,040	86,600	86,600	55,600	55,600	55,860	55,860	60,600	60,600	60,860	60,860
29	82,200	82,200	86,740	86,740	55,740	55,740	56,010	56,010	60,740	60,740	61,010	61,010
30	82,360	82,360	86,880	86,880	55,880	55,880	56,160	56,160	60,880	60,880	61,160	61,160
31	82,520	82,520	87,020	87,020	56,020	56,020	56,310	56,310	61,020	61,020	61,310	61,310
32	82,680	82,680	87,160	87,160	56,160	56,160	56,460	56,460	61,160	61,160	61,460	61,460
33	82,840	82,840	87,300	87,300	56,300	56,300	56,610	56,610	61,300	61,300	61,610	61,610
34	83,000	83,000	87,440	87,440	56,440	56,440	56,760	56,760	61,440	61,440	61,760	61,760
35	83,160	83,160	87,580	87,580	56,580	56,580	56,910	56,910	61,580	61,580	61,910	61,910
36	83,320	83,320	87,720	87,720	56,720	56,720	57,060	57,060	61,720	61,720	62,060	62,060
37	83,480	83,480	87,860	87,860	56,860	56,860	57,210	57,210	61,860	61,860	62,210	62,210
38	83,640	83,640	88,000	88,000	57,000	57,000	57,360	57,360	62,000	62,000	62,360	62,360
39	83,800	83,800	88,140	88,140	57,140	57,140	57,510	57,510	62,140	62,140	62,510	62,510
40	83,960	83,960	88,280	88,280	57,280	57,280	57,660	57,660	62,280	62,280	62,660	62,660
41	84,120	84,120	88,420	88,420	57,420	57,420	57,810	57,810	62,420	62,420	62,810	62,810
42	84,280	84,280	88,560	88,560	57,560	57,560	57,960	57,960	62,560	62,560	62,960	62,960
43	84,440	84,440	88,700	88,700	57,700	57,700	58,110	58,110	62,700	62,700	63,110	63,110
44	84,600	84,600	88,840	88,840	57,840	57,840	58,260	58,260	62,840	62,840	63,260	63,260
45	84,760	84,760	88,980	88,980	57,980	57,980	58,410	58,410	62,980	62,980	63,410	63,410
46	84,870	84,870	89,120	89,120	58,120	58,120	58,560	58,560	63,120	63,120	63,560	63,560
47	84,940	84,940	89,260	89,260	58,260	58,260	58,710	58,710	63,260	63,260	63,710	63,710
48	84,980	84,980	89,400	89,400	58,400	58,400	58,860	58,860	63,400	63,400	63,860	63,860

Номера и диаметры  $D_1$  зубьев

шлицевых

черновых и переходных

Размеры в мм

Обозначение протяжки	2403-1105	2403-1106	2403-1107 2403-1108	2403-1109 2403-1111	2403-1112 2403-1113	2403-1114 2403-1115	2403 1116	2403-1117	2403-1118 2403-1119	2403-1121 2403-1122	2403-1123	2403 1124		
	Н7-9Н	Н8-11Н	Н7-9Н	Н8-11Н	Н7-9Н	Н8-11Н	Н7-9Н	Н8-11Н	Н7-9Н	Н8-11Н	Н7-9Н	Н8-11Н		
<i>D</i> × <i>t</i>	85×3,5		90×3,5		60×4				65×4					
Номера и диаметры <i>D</i> и зубьев шлицевых	чистовых	49	85,000	85,010	89,540	89,540	58,540	58,540	59,010	59,010	63,540	63,540	64,010	64,010
		50	85,020	85,035	89,680	89,680	58,680	58,680	59,160	59,160	63,680	63,680	64,160	64,160
		51	85,035	85,054	89,820	89,820	58,820	58,820	59,310	59,310	63,820	63,820	64,310	64,310
		52	85,035	85,054	89,890	89,890	58,960	58,960	59,460	59,460	63,960	63,960	64,460	64,460
		53			89,950	89,950	59,100	59,100	59,610	59,610	64,100	64,100	64,610	64,610
		54			89,980	89,980	59,240	59,240	59,760	59,760	64,240	64,240	64,760	64,760
		55			90,000	90,010	59,380	59,380	59,880	59,880	64,380	64,380	64,880	64,880
		56			90,020	90,035	59,520	59,520	59,940	59,940	64,520	64,520	64,940	64,940
		57			90,035	90,054	59,660	59,660	59,970	59,970	64,660	64,660	64,970	64,970
		58	—	—	90,035	90,054	59,800	59,800	59,990	60,000	64,800	64,800	64,990	65,000
	59	59,890					59,890	60,010	60,025	64,880	64,880	65,010	65,025	
	60	59,940					59,940	60,030	60,046	64,940	64,940	65,030	65,046	
	61	59,970					59,970	60,030	60,046	64,970	64,970	65,030	65,046	
	62	59,990	60,000	64,990	65,000									
	63					60,010	60,025			65,010	65,025			
	64	—	—			60,030	60,046			65,030	65,046			
	65													
	66													
	67													
	68			—	—	60,030	60,046	—	—	65,030	65,046	—	—	
69														
70														

## Размеры в мм

Обозначение протяжки		2403-1125	2403-1127	2403-1129	2403-1132	2403-1134	2403-1136	2403-1138	2403-1141	2403-1143	2403-1145		
		2403-1126	2403-1128	2403-1131	2403-1133	2403-1135	2403-1137	2403-1139	2403-1142	2403-1144	2403-1146		
Сочетание полей допусков $D$ и $e$		H7-9H	H8-11H	H7-9H	H8-11H	H7-9H	H8-11H	H7-9H	H8-11H	H7-9H	H8-11H		
$D \times m$		70×4		75×4		80×4		85×4		90×4			
Номера и диаметры $D_f$ зубьев	фасочных	1	62,000	62,000	67,000	67,000	72,000	72,000	77,000	77,000	82,000	82,000	
		2	62,140	62,140	67,140	67,140	72,140	72,140	77,140	77,140	82,140	82,140	
		3	62,280	62,280	67,280	67,280	72,280	72,280	77,280	77,280	82,280	82,280	
		4	62,420	62,420	67,420	67,420	72,420	72,420	77,420	77,420	82,420	82,420	
		5	62,560	62,560	67,560	67,560	72,560	72,560	77,560	77,560	82,560	82,560	
		6	62,700	62,700	67,700	67,700	72,700	72,700	77,700	77,700	82,700	82,700	
		7	62,840	62,840	67,840	67,840	72,840	72,840	77,840	77,840	82,840	82,840	
		8	62,980	62,980	67,980	67,980	72,980	72,980	77,980	77,980	82,980	82,980	
		9	63,120	63,120	68,120	68,120	73,120	73,120	78,120	78,120	83,120	83,120	
		10	63,260	63,260	68,260	68,260	73,260	73,260	78,260	78,260	83,260	83,260	
	шлицевых	черновых и переходных	11	63,220	63,220	68,400	68,400	73,400	73,400	78,220	78,220	83,400	83,400
			12	63,360	63,360	68,360	68,360	73,360	73,360	78,360	78,360	83,360	83,360
			13	63,500	63,500	68,500	68,500	73,500	73,500	78,500	78,500	83,500	83,500
			14	63,640	63,640	68,640	68,640	73,640	73,640	78,640	78,640	83,640	83,640
			15	63,780	63,780	68,780	68,780	73,780	73,780	78,780	78,780	83,780	83,780
			16	63,920	63,920	68,920	68,920	73,920	73,920	78,920	78,920	83,920	83,920
			17	64,060	64,060	69,060	69,060	74,060	74,060	79,060	79,060	84,060	84,060
			18	64,200	64,200	69,200	69,200	74,200	74,200	79,200	79,200	84,200	84,200
			19	64,340	64,340	69,340	69,340	74,340	74,340	79,340	79,340	84,340	84,340
			20	64,480	64,480	69,480	69,480	74,480	74,480	79,480	79,480	84,480	84,480
			21	64,620	64,620	69,620	69,620	74,620	74,620	79,620	79,620	84,620	84,620
			22	64,760	64,760	69,760	69,760	74,760	74,760	79,760	79,760	84,760	84,760
			23	64,900	64,900	69,900	69,900	74,900	74,900	79,900	79,900	84,900	84,900
			24	65,040	65,040	70,040	70,040	75,040	75,040	80,040	80,040	85,040	85,040
			25	65,180	65,180	70,180	70,180	75,180	75,180	80,180	80,180	85,180	85,180

## Размеры в мм

Обозначение протяжки	2403-1125 2403-1126	2403-1127 2403-1128	2403-1129 2403-1131	2403-1132 2403-1133	2403-1134 2403-1135	2403-1136 2403-1137	2403-1138 2403-1139	2403-1141 2403-1142	2403-1143 2403-1144	2403-1145 2403-1146
	Н7—9Н	Н8—11Н	Н7—9Н	Н8—11Н	Н7—9Н	Н8—11Н	Н7—9Н	Н8—11Н	Н7—9Н	Н8—11Н
$D \times m$	70×4		75×4		80×4		85×4		90×4	
26	65,320	65,320	70,320	70,320	75,320	75,320	80,320	80,320	85,320	85,320
27	65,460	65,460	70,460	70,460	75,460	75,460	80,460	80,460	85,460	85,460
28	65,600	65,600	70,600	70,600	75,600	75,600	80,600	80,600	85,600	85,600
29	65,740	65,740	70,740	70,740	75,740	75,740	80,740	80,740	85,740	85,740
30	65,880	65,880	70,880	70,880	75,880	75,880	80,880	80,880	85,880	85,880
31	66,020	66,020	71,020	71,020	76,020	76,020	81,020	81,020	86,020	86,020
32	66,160	66,160	71,160	71,160	76,160	76,160	81,160	81,160	86,160	86,160
33	66,300	66,300	71,300	71,300	76,300	76,300	81,300	81,300	86,300	86,300
34	66,440	66,440	71,440	71,440	76,440	76,440	81,440	81,440	86,440	86,440
35	66,580	66,580	71,580	71,580	76,580	76,580	81,580	81,580	86,580	86,580
36	66,720	66,720	71,720	71,720	76,720	76,720	81,720	81,720	86,720	86,720
37	66,860	66,860	71,860	71,860	76,860	76,860	81,860	81,860	86,860	86,860
38	67,000	67,000	72,000	72,000	77,000	77,000	82,000	82,000	87,000	87,000
39	67,140	67,140	72,140	72,140	77,140	77,140	82,140	82,140	87,140	87,140
40	67,280	67,280	72,280	72,280	77,280	77,280	82,280	82,280	87,280	87,280
41	67,420	67,420	72,420	72,420	77,420	77,420	82,420	82,420	87,420	87,420
42	67,560	67,560	72,560	72,560	77,560	77,560	82,560	82,560	87,560	87,560
43	67,700	67,700	72,700	72,700	77,700	77,700	82,700	82,700	87,700	87,700
44	67,840	67,840	72,840	72,840	77,840	77,840	82,840	82,840	87,840	87,840
45	67,980	67,980	72,980	72,980	77,980	77,980	82,980	82,980	87,980	87,980
46	68,120	68,120	73,120	73,120	78,120	78,120	83,120	83,120	88,120	88,120
47	68,260	68,260	73,260	73,260	78,260	78,260	83,260	83,260	88,260	88,260
48	68,400	68,400	73,400	73,400	78,400	78,400	83,400	83,400	88,400	88,400
49	68,540	68,540	73,540	73,540	78,540	78,540	83,540	83,540	88,540	88,540
50	68,680	68,680	73,680	73,680	78,680	78,680	83,680	83,680	88,680	88,680

Номера и диаметры  $D$  и зубьев

шлицевых

черновых и переходных



## Размеры в мм

Обозначение протяжки		2403-1125 2403-1126	2403-1127 2403-1128	2403-1129 2403-1131	2403-1132 2403-1133	2403-1134 2403-1135	2403-1136 2403-1137	2403-1138 2403-1139	2403-1141 2403-1142	2403-1143 2403-1144	2403-1145 2403-1146		
Сочетание полей допусков <i>D</i> и <i>e</i>		H7-9H	H8-11H	H7-9H	H8-11H	H7-9H	H8-11H	H7-9H	H8-11H	H7-9H	H8-11H		
<i>D</i> × <i>t</i>		70×4		75×4		80×4		85×4		90×4			
Номера и диаметры <i>D</i> , зубьев	шлицевых	черновых и переходных	51	68,820	68,820	73,820	73,820	78,820	78,820	83,820	83,820	88,820	88,820
			52	68,960	68,960	73,960	73,960	78,960	78,960	83,960	83,960	88,960	88,960
			53	69,100	69,100	74,100	74,100	79,100	79,100	84,100	84,100	89,100	89,100
			54	69,240	69,240	74,240	74,240	79,240	79,240	84,240	84,240	89,240	89,240
			55	69,380	69,380	74,380	74,380	79,380	79,380	84,380	84,380	89,380	89,380
			56	69,520	69,520	74,520	74,520	79,520	79,520	84,520	84,520	89,520	89,520
			57	69,660	69,660	74,660	74,660	79,660	79,660	84,660	84,660	89,660	89,660
			58	69,800	69,800	74,800	74,800	79,800	79,800	84,800	84,800	89,800	89,800
			59	69,880	69,880	74,880	74,880	79,880	79,880	84,890	84,890	89,890	89,890
			60	69,940	69,940	74,940	74,940	79,940	79,940	84,950	84,950	89,950	89,950
	шлицевых	чистовых	61	69,970	69,970	74,970	74,970	79,970	79,970	84,980	84,980	89,980	89,980
			62	69,990	70,000	74,990	75,000	79,990	80,000	85,000	85,010	90,000	90,010
			63	70,010	70,025	75,010	75,025	80,010	80,025	85,020	85,035	90,020	90,035
			64	70,030	70,046	75,030	75,046	80,030	80,046	85,035	85,054	90,035	90,054
	шлицевых	калибрующих	65	70,030	70,046	75,030	75,046	80,030	80,046	85,035	85,054	90,035	90,054
			66										
			67										
			68										
			69										
			70										

## Размеры в мм

Обозначение протяжки		2403-1147	2403-1148	2403-1149	2403-1151	2403-1152	2403-1153	2403-1154	2403-1155	2403-1156	2403-1157		
Сочетание полей допусков $D$ и $e$		H7-9H	H8-11H	H7-9H	H8-11H	H7-9H	H8-11H	H7-9H	H8-11H	H7-9H	H8-11H		
$D \times m$		70×5		75×5		80×5		85 5		90×5			
Номера и диаметры $D_i$ зубьев	Фасочных	1	60,000	60,000	65,000	65,000	70,000	70,000	75,000	75,000	80,000	80,000	
		2	60,180	60,180	65,180	65,180	70,180	70,180	75,180	75,180	80,180	80,180	
		3	60,360	60,360	65,360	65,360	70,360	70,360	75,360	75,360	80,360	80,360	
		4	60,540	60,540	65,540	65,540	70,540	70,540	75,540	75,540	80,540	80,540	
		5	60,720	60,720	65,720	65,720	70,720	70,720	75,720	75,720	80,720	80,720	
		6	60,900	60,900	65,900	65,900	70,900	70,900	75,900	75,900	80,900	80,900	
		7	61,080	61,080	66,080	66,080	71,080	71,080	76,080	76,080	81,080	81,080	
		8	61,260	61,260	66,260	66,260	71,260	71,260	76,260	76,260	81,260	81,260	
		9	61,440	61,440	66,440	66,440	71,440	71,440	76,440	76,440	81,440	81,440	
	Шлицевых	Черновых и переходных	10	61,400	61,400	66,620	66,620	71,620	71,620	76,620	76,620	81,400	81,400
			11	61,580	61,580	66,580	66,580	71,580	71,580	76,580	76,580	81,580	81,580
			12	61,760	61,760	66,760	66,760	71,760	71,760	76,760	76,760	81,760	81,760
			13	61,940	61,940	66,940	66,940	71,940	71,940	76,940	76,940	81,940	81,940
			14	62,120	62,120	67,120	67,120	72,120	72,120	77,120	77,120	82,120	82,120
			15	62,300	62,300	67,300	67,300	72,300	72,300	77,300	77,300	82,300	82,300
			16	62,480	62,480	67,480	67,480	72,480	72,480	77,480	77,480	82,480	82,480
			17	62,660	62,660	67,660	67,660	72,660	72,660	77,660	77,660	82,660	82,660
			18	62,840	62,840	67,840	67,840	72,840	72,840	77,840	77,840	82,840	82,840
			19	63,020	63,020	68,020	68,020	73,020	73,020	78,020	78,020	83,020	83,020
			20	63,200	63,200	68,200	68,200	73,200	73,200	78,200	78,200	83,200	83,200
			21	63,380	63,380	68,380	68,380	73,380	73,380	78,380	78,380	83,380	83,380
			22	63,560	63,560	68,560	68,560	73,560	73,560	78,560	78,560	83,560	83,560
			23	63,740	63,740	68,740	68,740	73,740	73,740	78,740	78,740	83,740	83,740
			24	63,920	63,920	68,920	68,920	73,920	73,920	78,920	78,920	83,920	83,920
			25	64,100	64,100	69,100	69,100	74,100	74,100	79,100	79,100	84,100	84,100

## Размеры в мм

Обозначение протяжки		2403-1147	2403-1148	2403-1149	2403-1151	2403-1152	2403-1153	2403-1154	2403-1155	2403-1156	2403-1157		
		Н7-9Н	Н8-11Н	Н7-9Н	Н8-11Н	Н7-9Н	Н8-11Н	Н7-9Н	Н8-11Н	Н7-9Н	Н8-11Н		
Сочетание полей допусков <i>D</i> и <i>e</i>													
<i>D</i> × <i>t</i>		70×5		75×5		80×5		85×5		90×5			
Номера и диаметры <i>D</i> и зубьев	шлицевых	черновых и переходных	26	64,280	64,280	69,280	69,280	74,280	74,280	79,280	79,280	84,280	84,280
			27	64,460	64,460	69,460	69,460	74,460	74,460	79,460	79,460	84,460	84,460
			28	64,640	64,640	69,640	69,640	74,640	74,640	79,640	79,640	84,640	84,640
			29	64,820	64,820	69,820	69,820	74,820	74,820	79,820	79,820	84,820	84,820
			30	65,000	65,000	70,000	70,000	75,000	75,000	80,000	80,000	85,000	85,000
			31	65,180	65,180	70,180	70,180	75,180	75,180	80,180	80,180	85,180	85,180
			32	65,360	65,360	70,360	70,360	75,360	75,360	80,360	80,360	85,360	85,360
			33	65,540	65,540	70,540	70,540	75,540	75,540	80,540	80,540	85,540	85,540
			34	65,720	65,720	70,720	70,720	75,720	75,720	80,720	80,720	85,720	85,720
			35	65,900	65,900	70,900	70,900	75,900	75,900	80,900	80,900	85,900	85,900
			36	66,080	66,080	71,080	71,080	76,080	76,080	81,080	81,080	86,080	86,080
			37	66,260	66,260	71,260	71,260	76,260	76,260	81,260	81,260	86,260	86,260
			38	66,440	66,440	71,440	71,440	76,440	76,440	81,440	81,440	86,440	86,440
			39	66,620	66,620	71,620	71,620	76,620	76,620	81,620	81,620	86,620	86,620
			40	66,800	66,800	71,800	71,800	76,800	76,800	81,800	81,800	86,800	86,800
			41	66,980	66,980	71,980	71,980	76,980	76,980	81,980	81,980	86,980	86,980
			42	67,160	67,160	72,160	72,160	77,160	77,160	82,160	82,160	87,160	87,160
			43	67,340	67,340	72,340	72,340	77,340	77,340	82,340	82,340	87,340	87,340
			44	67,520	67,520	72,520	72,520	77,520	77,520	82,520	82,520	87,520	87,520
			45	67,700	67,700	72,700	72,700	77,700	77,700	82,700	82,700	87,700	87,700
			46	67,880	67,880	72,880	72,880	77,880	77,880	82,880	82,880	87,880	87,880
			47	68,060	68,060	73,060	73,060	78,060	78,060	83,060	83,060	88,060	88,060
			48	68,240	68,240	73,240	73,240	78,240	78,240	83,240	83,240	88,240	88,240
			49	68,420	68,420	73,420	73,420	78,420	78,420	83,420	83,420	88,420	88,420
			50	68,600	68,600	73,600	73,600	78,600	78,600	83,600	83,600	88,600	88,600

## Размеры в мм

Обозначение протяжки		2403-1147	2403-1148	2403-1149	2403-1151	2403-1152	2403-1153	2403-1154	2403-1155	2403-1156	2403-1157		
		Н7—9Н	Н8—11Н	Н7—9Н	Н8—11Н	Н7—9Н	Н8—11Н	Н7—9Н	Н8—11Н	Н7—9Н	Н8—11Н		
Сочетание полей допусков <i>D</i> и <i>e</i>													
<i>D</i> × <i>m</i>		70×5		75×5		80×5		85×5		90×5			
Номера и диаметры <i>D<sub>i</sub></i> зубьев	шлицевых	черновых и переходных	51	68,780	68,780	73,780	73,780	78,780	78,780	83,780	83,780	88,780	88,780
			52	68,960	68,960	73,960	73,960	78,960	78,960	83,960	83,960	88,960	88,960
			53	69,140	69,140	74,140	74,140	79,140	79,140	84,140	84,140	89,140	89,140
			54	69,320	69,320	74,320	74,320	79,320	79,320	84,320	84,320	89,320	89,320
			55	69,500	69,500	74,500	74,500	79,500	79,500	84,500	84,500	89,500	89,500
			56	69,680	69,680	74,680	74,680	79,680	79,680	84,680	84,680	89,680	89,680
			57	69,840	69,840	74,840	74,840	79,840	79,840	84,850	84,850	89,850	89,850
			58	69,930	69,930	74,930	74,930	79,930	79,930	84,940	84,940	89,940	89,940
	шлицевых	чистовых	59	69,970	69,970	74,970	74,970	79,970	79,970	84,980	84,980	89,980	89,980
			60	69,990	70,000	74,990	75,000	79,990	80,000	85,000	85,010	90,000	90,010
			61	70,010	70,025	75,010	75,025	80,010	80,025	85,020	85,035	90,020	90,035
			62	70,030	70,046	75,030	75,046	80,030	80,046	85,035	85,054	90,035	90,054
	шлицевых	калибрующих	63	70,030	70,046	75,030	75,046	80,030	80,046	85,035	85,054	90,035	90,054
			64										
			65										
			66										
			67										
			68										

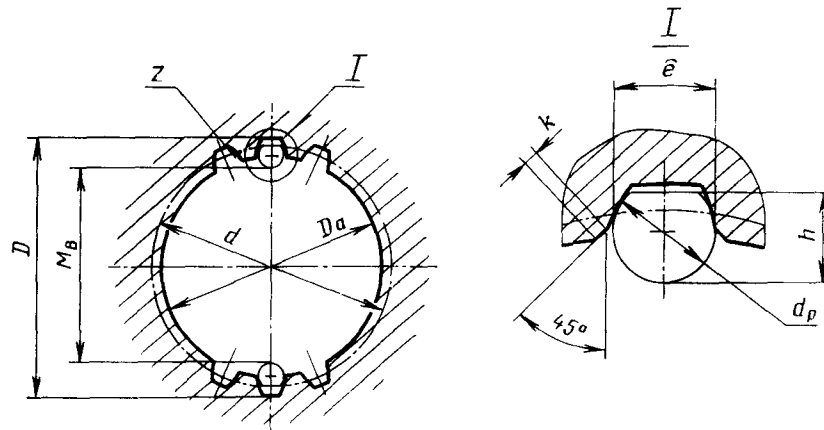

Черт. 2

Таблица 4

Размеры в мм

Обозначение протяжки	$D \times t$	z	Сочетание полей допусков D и e	d	e	$D_a$ (поле допуска Н11)	k	$d_p$	h	$M_e$		Длина протягивания		Усилие протягивания P, Н(кгс) при переднем угле		
										Наим.	Верхн. откл.	Сталь и алюминиевые сплавы	Чугун, бронза, латунь	20°	15°	10°
2403-0961; 2403-0962	45×3	13	H7—9H	39	6,271	39	0,45	5,455	5,2	33,257	+0,077	30—76	30—90	99800 (10170)	109200 (11130)	117400 (11970)
2403-0963; 2403-0964			H8—11H							33,299	+0,153					
2403-0965; 2403-0966			H7—9H							33,257	+0,077	40—102	40—120	124600 (12700)	136350 (13900)	146650 (14950)
2403-0967; 2403-0968			H8—11H							33,299	+0,153					
2403-0969; 2403-0971	48×3	14	H7—9H	42	6,271	42	0,45	5,455	5,2	36,542	+0,077	30—76	30—90	106350 (10840)	116350 (11860)	125100 (12750)
2403-0972; 2403-0973			H8—11H							36,583	+0,155					
2403-0974; 2403-0975			H7—9H							36,542	+0,077	40—102	40—120	132400 (13500)	145200 (14800)	156000 (15900)
2403-0976; 2403-0977			H8—11H							36,583	+0,155					
2403-0978; 2403-0979	50×3	15	H7—9H	45	5,694	44	0,45	5,455	5,2	38,264	+0,083	30—76	30—90	111150 (11330)	121650 (12400)	130750 (13330)
2403-0981; 2403-0982			H8—11H							38,308	+0,166					
2403-0983; 2403-0984			H7—9H							38,264	+0,083	40—108	40—130	162850 (16600)	178050 (18150)	191300 (19500)
2403-0985; 2403-0986			H8—11H							38,308	+0,166					

Размеры в мм

Обозначение протяжки	D×t	z	Сочетание полей допусков D и e	d	e	D <sub>a</sub> (поле допуска H11)	k	d <sub>p</sub>	h	M <sub>e</sub>		Длина протягивания		Усилие протягивания P, Н(кгс) при переднем угле		
										Наим.	Верхн. откл.	Сталь и алюминные сплавы	Чугун, бронза, латунь	5°	15°	10°
2403-0987; 2403-0988	52×3	16	H7-9H	48	5,117	46			5,2	40,382	+0,091	30-76	30-90	119100 (12140)	130300 (13280)	140100 (14280)
2403-0989; 2403-0991			H8-11H							40,431	+0,182					
2403-0992; 2403-0993	55×3	17	H7-9H	51	5,117	49				40,382	+0,091	40-108	40-130	174300 (17770)	190700 (19440)	205000 (20900)
2403-0994; 2403-0995			H8-11H							40,431	+0,182					
2403-0996; 2403-0997	60×3	18	H7-9H	54	6,271	54				43,193	+0,101	32-82	32-100	142450 (14520)	155800 (15880)	167450 (17070)
2403-0998; 2403-0999			H8-11H							43,254	+0,199					
2403-1001; 2403-1002	65×3	20	H7-9H	60	5,694	59	0,45	5,455		43,193	+0,101	45-120	45-145	190300 (19400)	208000 (21200)	223650 (22800)
2403-1003; 2403-1004			H8-11H							43,254	+0,199					
2403-1005; 2403-1006	70×3	22	H7-9H	66	5,117	64			5,2	48,549	+0,086	32-82	32-100	155700 (15870)	170300 (17360)	183150 (18670)
2403-1007; 2403-1008			H8-11H							48,600	+0,172					
2403-1009; 2403-1011	75×3	24	H7-9H	72	4,539	69				48,549	+0,086	45-120	45-145	207600 (21160)	227100 (23150)	244250 (24900)
2403-1012; 2403-1013			H8-11H							48,600	+0,172					
2403-1014; 2403-1015	80×3	25	H7-9H	75	5,694	74				53,522	+0,091	32-82	32-100	173050 (17640)	189300 (19300)	203550 (20750)
2403-1016; 2403-1017			H8-11H							53,577	+0,182					
2403-1018; 2403-1019	70×3	22	H7-9H	66	5,117	64				53,522	+0,091	45-130	45-160	256200 (26120)	280400 (28580)	301150 (30700)
2403-1021; 2403-1022			H8-11H							53,577	+0,182					
2403-1023; 2403-1024	75×3	24	H7-9H	72	4,539	69				58,442	+0,097	32-96	32-110	216100 (22030)	236400 (24100)	254100 (25900)
2403-1025; 2403-1026			H8-11H							58,500	+0,192					
2403-1027; 2403-1028	80×3	25	H7-9H	75	5,694	74				58,442	+0,097	45-140	45-170	274700 (28000)	300200 (30600)	322750 (32900)
2403-1029; 2403-1031			H8-11H							58,500	+0,192					
2403-1032; 2403-1033	75×3	24	H7-9H	72	4,539	69				63,308	+0,102	32-96	32-110	234450 (23900)	256400 (26140)	275650 (28100)
2403-1034; 2403-1035			H8-11H							63,369	+0,203					
2403-1036; 2403-1037	80×3	25	H7-9H	75	5,694	74				63,308	+0,102	45-140	45-170	297500 (30330)	325500 (33180)	350200 (35700)
2403-1038; 2403-1039			H8-11H							63,369	+0,203					
2403-1041; 2403-1042	75×3	24	H7-9H	72	4,539	69				68,382	+0,090	32-96	32-110	251150 (25600)	274700 (28000)	295300 (30100)
2403-1043; 2403-1044			H8-11H							68,436	+0,179					
2403-1045	80×3	25	H7-9H	75	5,694	74				68,382	+0,090	48-150	48-180	303100 (30900)	331600 (33800)	356600 (36350)
2403-1046			H8-11H							68,436	+0,179					

Размеры в мм

Продолжение табл 4

Обозначение протажки	D×m	z	Сочетание поди допус- ков D и e	d	e	D <sub>a</sub> (поле допус- ка H11)	k	d <sub>p</sub>	h	M <sub>s</sub>		Длина протягивания		Усилие протягивания P, Н(кгс) при переднем угле		
										Наим	Верхн. откл.	Сталь и алюмини- евые спла- вы	Чугун, бронза, латунь	20°	15°	10°
2403-1047; 2403-1048	85×3	27	H7-9H	81	5,117	79	0,45	5,455	5,2	73,332	+0,094	32-96	32-110	265250 (27040)	290200 (29580)	311950 (31800)
2403 1049; 2403-1051			H8-11H							73,388	+0,188					
2403-1052			H7-9H							73,332	+0,094	50-157	50-190	319800 (32600)	350000 (35680)	376200 (38350)
2403-1053			H8-11H							73,388	+0,188					
2403-1054; 2403-1055	90×3	28	H7-9H	84	6,271	84	0,45	5,455	5,2	78,549	+0,086	32-96	32-110	286450 (29200)	313150 (31920)	336500 (34300)
2403-1056; 2403-1057			H8-11H							78,601	+0,172					
2403-1058			H7-9H							78,549	+0,086	48-150	48-180	309000 (31500)	338050 (34460)	363450 (37050)
2403-1059			H8-11H							78,601	+0,172					
2403-1061; 2403-1062	55×3,5	14	H7-9H	49	6,739	48	0,45	5,455	5,2	41,101	+0,086	32-82	32-100	137350 (14000)	150300 (15320)	161600 (16470)
2403-1063; 2403-1064			H8-11H							41,147	+0,170					
2403-1065			H7-9H							41,101	+0,086	45-120	42-145	183650 (18720)	200900 (20480)	215800 (22000)
2403 1066			H8-11H							41,147	+0,170					
2403-1067; 2403-1068	60×3,5	16	H7-9H	56	5,584	53	0,45	5,455	5,8	46,823	+0,106	32-82	32-100	154400 (15740)	168900 (17220)	181500 (18500)
2403-1069; 2403-1071			H8-11H							46,887	+0,210					
2403-1072			H7-9H							46,823	+0,106	45-120	45-145	206200 (21020)	225600 (23000)	242300 (24700)
2403-1073			H8-11H							46,887	+0,210					
2403-1074; 2403-1075	65×3,5	18	H7-9H	63	4,430	58	0,52	6,212	5,8	51,143	+0,138	32-82	32-100	163250 (16640)	178550 (18200)	192000 (19570)
2403-1076; 2403-1077			H8-11H							51,226	+0,271					
2403-1078			H7-9H							51,143	+0,138	45-130	45-160	241300 (24600)	264200 (26930)	284000 (28950)
2403-1079			H8-11H							51,226	+0,271					
2403-1081; 2403-1082	70, 3 5	18	H7-9H	63	7,316	63	0,45	6,518	5,8	56,167	+0,088	32-96	32-110	210900 (21500)	230550 (23500)	247900 (25270)
2403-1083; 2403-1084			H8-11H							56,220	+0,174					
2403-1085			H7-9H							56,167	+0,088	45-140	45-170	267300 (27250)	292550 (29820)	314500 (32060)
2403-1086			H8-11H							56,220	+0,174					
2403-1087; 2403-1088	75×3,5	20	H7-9H	70	6,162	68	0,45	6,212	5,8	62,018	+0,094	32-96	32-110	231500 (23600)	253100 (25800)	272100 (27740)
2403-1089; 2403-1091			H8-11H							62,074	+0,188					
2403-1092			H7-9H							62,018	+0,094	45-140	45-170	293300 (29900)	321100 (32730)	345300 (35200)
2403-1093			H8-11H							62,074	+0,188					

## Размеры в мм

Обозначение протяжки	$D \times m$	$z$	Сочетание полей допусков $D$ и $e$	$d$	$e$	$D_a$ (поле допуска H11)	$k$	$d_p$	$h$	$M_g$		Длина протягивания		Усилие протягивания $P, N$ (кгс) при переднем угле		
										Наим.	Верхн. откл.	Сталь и алюминиевые сплавы	Чугун, бронза, латунь	20°	15°	10°
2403-1094; 2403-1095	80×3,5	22	H7—9H	77	5,007	73	0,52	6,212	5,8	66,727	+0,107	32—96	32—110	243000 (24770)	265850 (27100)	285850 (29140)
2403-1096; 2403-1097			H8—11H							66,791	+0,211					
2403-1098			H7—9H							66,727	+0,107	45—140	45—170	308400 (31440)	337450 (34400)	363000 (37000)
2403-1099			H8—11H							66,791	+0,211					
2403-1101; 2403-1102	85×3,5	24	H7—9H	84	3,852	78	0,52	5,455	5,2	73,928	+0,108	32—96	32—110	256700 (26170)	280850 (28630)	301950 (30780)
2403-1103; 2403-1104			H8—11H							73,993	+0,214					
2403-1105			H7—9H							73,928	+0,108	45—140	45—170	309300 (31530)	338450 (34500)	363950 (37100)
2403-1106			H8—11H							73,993	+0,214					
2403-1107; 2403-1108	90×3,5		H7—9H							77,079	+0,089	32—96	32—110	282150 (28760)	308700 (31470)	332000 (33840)
2403-1109; 2403-1111			H8—11H							77,132	+0,177					
2403-1112; 2403-1113	60×4	13	H7—9H	52	8,362	52	0,60	7,000	6,6	45,144	+0,084	32—82	32—100	149600 (15250)	163600 (16680)	175600 (17900)
2403-1114; 2403-1115			H8—11H							45,195	+0,165					
2403-1116			H7—9H							45,144	+0,084	45—115	45—140	210900 (21500)	230550 (23500)	247900 (25270)
2403-1117			H8—11H							45,195	+0,165					
2403-1118; 2403-1119	65×4	15	H7—9H	60	6,630	57	0,60	7,000	6,6	50,026	+0,102	32—82	32—100	164100 (16730)	176900 (18030)	190300 (19400)
2403-1121; 2403-1122			H8—11H							50,087	+0,202					
2403-1123			H7—9H							50,026	+0,102	45—115	45—140	227800 (23220)	249200 (25400)	267800 (27300)
2403-1124			H8—11H							50,087	+0,202					
2403-1125; 2403-1126	70×4	16	H7—9H	64	7,207	62	0,60	7,000	6,6	55,478	+0,093	32—96	32—110	210900 (21500)	230550 (23500)	247900 (25270)
2403-1127; 2403-1128			H8—11H							55,534	+0,186					
2403-1129; 2403-1131	75×4	17	H7—9H	68	7,784	67	0,60	7,000	6,6	60,241	+0,088	32—96	32—110	225600 (23000)	246500 (25130)	265050 (27020)
2403-1132; 2403-1133			H8—11H							60,294	+0,175					
2403-1134; 2403-1135	80×4	18	H7—9H	72	8,362	72	0,60	7,000	6,6	65,530	+0,084	32—96	32—110	239750 (24440)	262300 (26740)	282050 (28750)
2403-1136; 2403-1137			H8—11H							65,580	+0,169					
2403-1138; 2403-1139	85×4	20	H7—9H	80	6,630	77	0,60	7,000	6,6	70,400	+0,097	32—96	32—110	260250 (26530)	284700 (29020)	306100 (31200)
2403-1141; 2403-1142			H8—11H							70,458	+0,193					
2403-1143; 2403-1144	90×4	21	H7—9H	84	7,207	82	0,60	7,000	6,6	75,262	+0,092	32—96	32—110	275650 (28100)	301550 (30740)	324200 (33050)
2403-1145; 2403-1146			H8—11H							75,317	+0,182					



## Размеры в мм

Обозначение протяжки	$D \times t$	$z$	Сочетание полей допусков $D$ и $e$	$d$	$e$	$D_a$ (поле допуска Н11)	$k$	$d_p$	$h$	$M_e$		Длина протягивания		Усилия протягивания $P, N$ (кгс) при переднем угле		
										Наим.	Верхи. откл.	Сталь и алюминие- вые спла- вы	Чугун, бронза, латунь	20°	15°	10°
2403-1147	70×5	12	H7—9H	60		60			8,3	52,078	+0,093			211600 (21570)	231500 (23600)	248900 (25370)
2403-1148			H8—11H							52,135	+0,185					
2403-1149	75×5	13	H7—9H	65		65			—	56,599	+0,093			225900 (23030)	247200 (25200)	265850 (27100)
2403-1151			H8—11H							56,656	+0,185					
2403-1152	80×5	14	H7—9H	70	10,452	70	0,75	8,690	8,3	62,080	+0,094	32—94	32—110	241300 (24600)	263900 (26900)	283500 (28900)
2403-1153			H8—11H							62,137	+0,187					
2403-1154	85×5	15	H7—9H	75		75			—	66,665	+0,094			257300 (26230)	281550 (28700)	302750 (30860)
2403-1155			H8—11H							66,722	+0,187					
2403-1156	90×5	16	H7—9H	80		80			8,3	72,081	+0,095			281550 (28700)	308050 (31400)	331200 (33760)
2403-1157			H8—11H							72,138	+0,188					

**Изменение № 1 ГОСТ 25160—82 Протяжки для шлицевых отверстий с эвольвентным профилем диаметром от 45 до 90 мм, модулем от 3 до 5 мм с центрированием по наружному диаметру. Конструкция и размеры**

**Постановлением Государственного комитета СССР по стандартам от 28.03.86 № 796 срок введения установлен**

**с 01.09.86**

Пункт 1 изложить в новой редакции: «1. Настоящий стандарт распространяется на однопроходные протяжки универсального назначения диаметром от 45 до 90 мм, модулем от 3 до 5 мм, предназначенные для обработки шлицевых втулок с эвольвентным профилем по ГОСТ 6033—80 с центрированием по наружному диаметру».

Пункт 2 дополнить абзацем: «Допускается по требованию заказчика корректировка размеров М (табл. 2) и диаметров чистовых и калибрующих зубьев (табл. 3)»;

(Продолжение см. с 90)

(Продолжение изменения к ГОСТ 25160—82)

таблица 1. Графа *D*<sub>1</sub>. Для протяжек 2403-1125 — 2403-1128 заменить значение: 63 на 50;

графа *i*. Заменить значения для протяжек: 2403-1074 — 2403-1079 — 8 на 18; для 2403-1101 — 2403-1106 — 5 на 15.

Пример условного обозначения дополнить абзацем: «То же, протяжки с откорректированными исполнительными размерами:

*Протяжка 2403—1011К П ГОСТ 25160—82»;*

таблица 2. Графа «На последнем калибрующем зубе». Для протяжек 2403-1041 — 2403-1042 заменить значение: 92,253 на 91,953;

таблица 3. Графа Н8—11Н. Заменить значения для протяжек: 2403-0985 — 2403-0986 и номера зуба 43 — 50,010 на 50,020; для 2403-1034 — 2403-1035 и номера зуба 39 — 75,140 на 74,140; для 2403—1053 и номера зуба 43 — 84,010 на 85,010; для 2403—1117 и номера зуба 47 — 68,710 на 58,170.

(ИУС № 7 1986 г.)

**Изменение № 2 ГОСТ 25160—82 Протяжки для шлицевых отверстий с эвольвентным профилем диаметром от 45 до 90 мм, модулем от 3 до 5 мм с центрированием по наружному диаметру. Конструкция и размеры**

**Утверждено и введено в действие Постановлением Государственного комитета СССР по стандартам от 23.09.87 № 3627**

**Дата введения 01.02.88**

Пункт 2. Чертеж 1. Размеры  $l_2$ ,  $l_3$ ,  $l_4$  дополнить знаком сноски \*; размеры 24,  $l_7$  и параметр  $n$  дополнить знаком сноски \*\*;

чертеж дополнить сноской \*\* «\*\* Размеры и параметр рекомендуемые»;

таблица 1. Графа L. Заменить значения: 1475 на 1500 (для протяжек 2403-1147, 2403-1148); 1500 на 1525 (для протяжек 2403-1149—2403-1157);

графа  $l_4$ . Заменить значения: 90 на 99 (для протяжек 2403-1112—2403-1115, 2403-1118—2403-1122, 2403-1125—2403-1146); 99 на 126 (для протяжек 2403-1147—2403-1156);

графа  $l_7$ . Заменить значения 14 на 12 (для протяжек 2403-1112—2403-1115, 2403-1125—2403-1128); 16 на 12 (для протяжек 2403-1118—2403-1122);

графа  $t_1$ . Заменить значения: 10 на 11 (для протяжек 2403-1112—2403-1115, 2403-1118—2403-1122, 2403-1125—2403-1146); 11 на 14 (для протяжек 2403-1147—2403-1157);

графа «Зубья чистовые и калибрующие (число зубьев 10). Номер профиля». Заменить значения: 5 на 6 (4 раза); 6 на 7 (для протяжек 2403-1061—2403-1064, 2403-1067—2403-1071, 2403-1074—2403-1077, 2403-1081—2403-1084, 2403-1087—2403-1091, 2403-1094—2403-1097, 2403-1101—2403-1104, 2403-1107—2403-1111); 6 на 8 (для протяжек 2403-1112—2403-1115, 2403-1118—2403-1122, 2403-1125—2403-1146);

(Продолжение см. с. 132)

*(Продолжение изменения к ГОСТ 25160—82)*

7 на 8 (для протяжек 2403-1116, 2403-1117, 2403-1123, 2403-1124); 7 на 10 (для протяжек 2403-1147—2403-1157);  
графа С. Заменить значения: 0,369 на 0,375 (для протяжек 2403-1147, 2403-1148); 0,375 на 0,381 (для протяжек 2403-1149—2403-1157);  
графа л. Заменить значение: 3 на 2 (для протяжек 2403-1129—2403-1146)

Пункт 7. Заменить обозначения: Н14 на Н16, h14 на h16,  $\pm \frac{IT14}{2}$  на  $\pm \frac{IT16}{2}$ .

(ИУС № 1 1988 г.)